

The Z Series

Zero-Fired SCR Power Controllers

60-1200 AMPS
120-600 VAC



SCR Power controllers
for resistance heating
applications.

Applications

Robicon's Z series power controls are an alternative to mechanical contactors. The Z Series typically has less bulk and longer service life than the devices mentioned. SCR Power Controls are used for applications such as industrial and laboratory furnaces, ovens and kilns, and many other types of resistive-heating control.

Type of Load

The Z series is designed to control directly-coupled resistive loads. The nominal load resistance should not vary more than 10% due to temperature or age. The 1Z is designed to control single phase loads. The 2Z and 3Z control three phase 3-wire delta or wye loads, and the 3Z can also control three phase 4-wire wye loads.

SCR Controllers for special applications include:

- Water-cooled
- Systems
- Enclosures

Output

Output Voltage

Controllable from 0 V to over 100% of VAC, RMS value of output is a linear function of the input control signal (current or voltage) over the range from 5% to 100% VAC. Within this linear operating range, long term resolution is infinite and output voltage regulation is $\pm 1\%$ for a $\pm 10\%$ line variation.

Output Current Rating

RMS line current ratings are based on continuous operation in free air at ambient temperatures of 122°F (50°C) or less.

SCR Failure Detector Option

This device senses a shorted SCR and provides a set of form-C relay contacts that the customer may use to alarm and/or turn off the process. The detector is a panel-mount unit that can be supplied for single and three phase applications.

Reliability and Performance

Fuse Protection

The Z series controllers are supplied with I²t coordinated current limiting fuses to protect the SCRs in each controlled leg. In addition, an I²t fuse is supplied in the uncontrolled leg of the 350-1200 A 2Z controller. A fuse kit is available for the uncontrolled leg of the 60-225 A 2Z controller.

Voltage Surge Protection

MOV-Capacitor-Resistor networks connected in parallel with each thyristor provide combined voltage surge and dv/dt protection. Thyristor ratings are selected to provide a minimum safety factor of 2.5X the nominal RMS of the AC supply voltage and typical suppressed dv/dt values.

Physical Construction

Open panel construction is standard. Units can also be supplied in free-standing or wall-mounted custom enclosures.

Ambient Temperature Ranges

Operating, 0°F (-20°C) to 122°F (50°C). Consult factory for deratings above 122°F (50°C) or above 6000 ft. ms/.



Features

Variable Time Base

The Z series output is determined by variable-time-base firing of the SCRs. At power levels other than 0 or 100%, the time base varies as a function of the control signal "power demand" level.

For example, a single phase 1Z at 50% power demand will be on for one cycle and off for one cycle. A three phase 2Z at 50% power demand will be on for two cycles per phase and off for two cycles per phase. A three phase 3Z at 50% power demand will be on for three cycles per phase and off for three cycles per phase.

The important advantage of variable-time-base is that off time is always minimized and is consistent with power demand. This reduces thermal cycling of the heating element which may prolong element life.

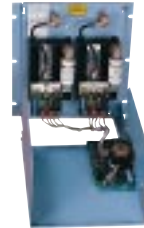

AC Supply

All units rated for nominal value VAC +10%, -20%. Standard voltage ratings: 120, 208, 240, 277, 400, 480 and 600 V.

Control Inputs

Standard input signals from temperature controllers or PLCs control the Z Series.

Gain and Bias Controls

The gain and bias controls are conveniently located on the front panel for calibration.

Features

- Conservative thermal design increases service life and minimizes maintenance
- Compact design
- Electrically isolated heat sinks (225 amps and below)
- Digital circuitry for precision control, linearity and noise immunity
- Variable-time-base reduces thermal shock to load
- Pulse-train gating ensures reliable SCR firing
- SCRs rated 1400 PIV
- Voltage regulated
- Power linear
- I²t fuses, MOVs and dv/dt networks protect SCRs
- Two-year warranty
- CSA Certified and UL Listed



Options

Lug Kits

The lug kits must be specified when placing an order for any unit rated 350-1200 amps. The lugs are standard on all units rated 60-225 amps.

Fuse Kits

The third leg fuse kit can be supplied for the 2Z 60-225 amp units. The fuse kit mounts separate from the 2Z.

Enclosures

Contact factory or representative for ordering information. The SCRs can be supplied in NEMA enclosures (vented or fan cooled).

SCR Failure Detector

This option is remotely mounted.

Formulas

- Calculation for three phase current when the line voltage and kW are known:
 $I (\text{Current}) = \text{Power kW} / (\text{Voltage (E)} \times \sqrt{3})$
example: 60 amps = 50 kW / (480 volts X 1.732)
- Calculation for single phase current when the line voltage and kW are known:
 $I (\text{Current}) = \text{Power kW} / \text{Voltage (E)}$
example: 104 amps = 50 kW / 480 volts
- Calculation for the heat generated by an SCR controller:
 $(1.5 \text{ volts}) \times (\text{the full load current}) \times (\text{the number of controlled legs}) = \text{total watts}$
example: 1.5 volts X 60 amps X 3 = 270 watts

Technical Specifications

INPUT LINE VOLTAGE:*	120, 208, 240, 400, 480 or 600 VAC; +10%, -20%; 50 or 60 Hz.
CURRENT RATING:*	60, 90, 120, 180, 225, 350, 500, 650, 800, 1000, 1200 amperes.
CONTROL METHODS:**	1) temperature or process controller 2) potentiometer; 5000 ohms, 1/2 watt (customer supplied) 3) dry contact closure (customer supplied) 4) BIAS control.
CONTROL SIGNAL INPUT INPEDANCE:	500 ohms, 1/2 watt standard (easily changed by customer to 1500 ohms).
CONTROL SIGNAL ISOLATION:	From SCRs—2500 VAC. From AC power input lines—2500 VAC. From chassis — 500 VAC.
VOLTAGE REGULATION:	1% per 10% line voltage change.
POWER SCR PROTECTION:	1) Subcycle I ² t semiconductor fuse. 2) Transient voltage spikes (dv/dt) across each SCR pair; all SCRs have 1400 PIV rating.
ZERO-FIRING TIME BASE:	Variable.
CONTROLS:	BIAS and GAIN potentiometers (1 turn, screwdriver adjustable, lockable).
AMBIENT TEMPERATURE RANGE:	Operation—max. 122°F (50°C). Storage—14°F to 158°F (-10°C to 70°C).

* Specify with order.

** Specify output when using a temperature/process controller.

Typical Input/Output Connections

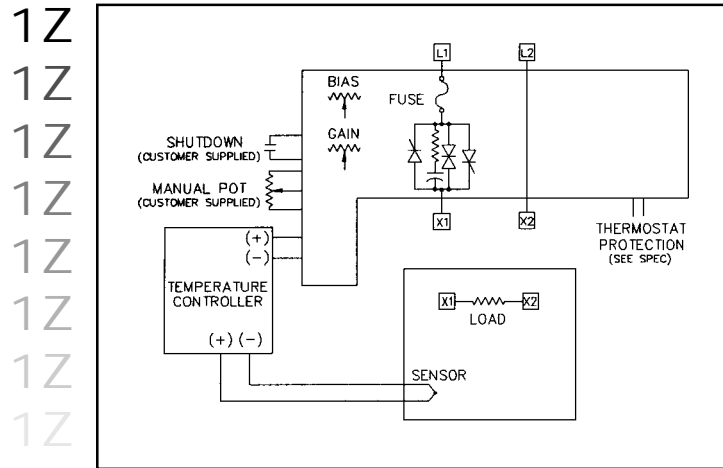

Typical Input/Output Connections for 1Z

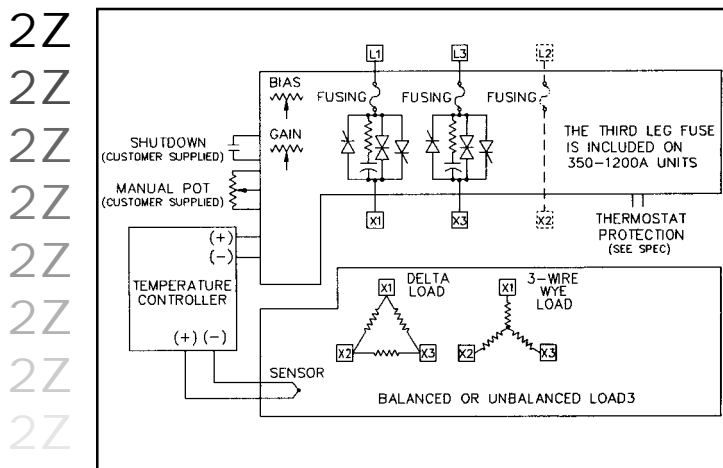

Typical Input/Output Connections for 2Z

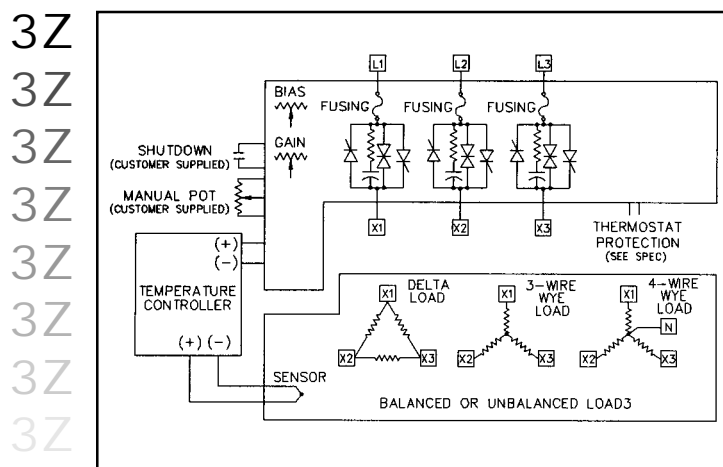

Typical Input/Output Connections for 3Z

Technical Data

1Z Series

Amp Range	Dimensions			Weight		Fan Cooling Power (as applicable)	
	Height	Width	Depth*	Lbs.	Kg.	50 Hz	60 Hz
60–120	9.00	9.00	9.062	16.5	7.5	NA	NA
180–225	14.75	11.00	9.250	20.0	9.1	0.21 amps, 25 VA	0.19 amps, 23 VA
350–500	21.00	14.25	8.500	24.0	10.6	0.21 amps, 25 VA	0.19 amps, 23 VA
650	24.00	16.75	12.000	47.0	21.4	1.40 amps, 168 VA	1.20 amps, 144 VA
800–1200	33.00	16.75	12.500	71.0	32.3	1.40 amps, 168 VA	1.20 amps, 144 VA

**Lug kits will increase the depth of the 350-1200 A units*

2Z Series

Amp Range	Dimensions			Weight		Fan Cooling Power (as applicable)	
	Height	Width	Depth*	Lbs.	Kg.	50 Hz	60 Hz
60	14.75	14	9.25	25	11.4	NA	NA
90–225	14.75	14	9.25	25	11.4	0.21 amps, 25 VA	0.19 amps, 23 VA
350–500	21.00	19	8.50	41	18.6	0.21 amps, 25 VA	0.19 amps, 23 VA
650	24.00	24	12.00	87	39.5	1.40 amps, 168 VA	1.20 amps, 144 VA
800–1200	33.00	27	12.50	180	81.8	1.40 amps, 168 VA	1.20 amps, 144 VA

**Lug kits will increase the depth of the 350-1200 A units*

3Z Series

Amp Range	Dimensions			Weight		Fan Cooling Power (as applicable)	
	Height	Width	Depth*	Lbs.	Kg.	50 Hz	60 Hz
60	14.75	19	9.25	40	18.2	NA	NA
90–225	14.75	19	9.25	40	18.2	0.42 amps, 50 VA	0.38 amps, 46 VA
350–500	30.75	19	8.50	60	27.3	0.63 amps, 76 VA	0.57 amps, 69 VA
650	36.00	24	12.00	126	57.3	4.20 amps, 504 VA	3.60 amps, 432 VA
800–1200	42.00	27	12.50	231	105.0	4.20 amps, 504 VA	3.60 amps, 432 VA

**Lug kits will increase the depth of the 350-1200 A units*

ORDERING INFORMATION

 Z —
 —
 —
 —
 —
 —

Phase
Voltage
Amperage
Input
Options
Lug Kit

PHASE	AMPERAGE	INPUT	OPTIONS
Single — 1	60 amps	0 – 5 ma — 1	Third Leg Fuse Kit – FK (2Z, 60-225 Amps only)
Three — 2 (2 leg control)	90 amps	0 – 20 ma — 2	NEMA-12 Enclosure – EC1 (vented) Enclosure – EC2 (with fan & filter)
Three — 3 (3 leg control)	120 amps	0 – 50 ma — 3	
	180 amps	1 – 5 ma — 4	
	225 amps	4 – 20 ma — 5	
	350 amps	12 – 20 ma — 6	
	500 amps	0 – 5 volts DC — 7	
	650 amps	0 – 10 volts DC — 8	
800 amps	Potentiometer — 9		
1000 amps			
1200 amps			
VOLTAGE			LUG KIT
120 volts — 12			Add “LK” if lugs are required for 350 through 1200 amp units. Lugs are standard for units 60 – 225 amps.
208 volts — 20			
240 volts — 24			
277 volts — 27			
400 volts — 40			
480 volts — 48			
600 volts — 60			

All fan cooled units are equipped with “normally open” heat sink thermostats. “Normally closed” are available upon request.