

The PCI Series

Phase Angle Fired SCR Power Controls

25-1200 AMPS
120-600 VAC

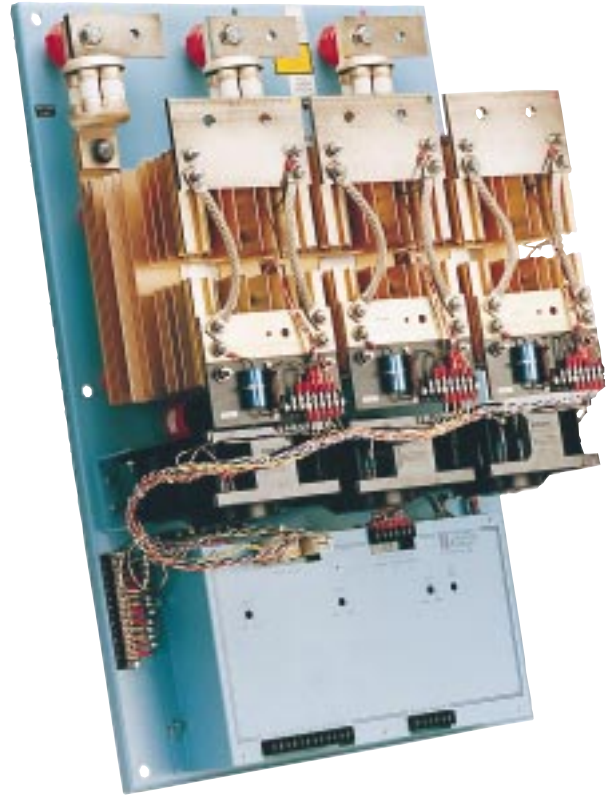

Precise power control for complex
SCR applications.

Applications

The PCI (phase-angle, cosine intercept) power controller series provides full wave output with full wave, phase-angle fired control. Typically, phase-angle fired silicon controlled rectifiers (SCRs) regulate transformer coupled loads or loads with transient characteristics. But other control circuits can be sensitive to line fluctuations, and fail due to line voltage noise. To correct this problem, Robicon has added cosine intercept linear phase control to efficiently diminish the effect of noise on the unit.

On one compact printed wiring board, the all-semiconductor gate trigger unit (GTU) combines the noise immunity of cosine intercept linear phase control with hard drive gate output circuits and a voltage regulator preamplifier. The GTU drives an inverse parallel-connected pair of SCRs for each phase controlled. The PCI Series can be operated into resistive or inductive loads driven directly or through an interposing transformer. Units are available with ratings of 25 to 1200 A and at 120 to 600 VAC.

Application-Specific Features

- DC output
- Water cooled (Harsh environment)
- Fuseless operation (Induction heating)
- Systems (Custom design)

Contact your sales representative for assistance.

Output

Output Voltage Regulation

Controllable from 0 V to over 100% of VAC, RMS value of output is a linear function of the input control signal over the range from 5% to 100% VAC. Within this linear operating range, long term resolution is infinite, and output voltage regulation is $\pm 0.5\%$ for a $\pm 10\%$ line variation.

Output Current Rating

RMS line current ratings are based on continuous operation in free air at ambient temperatures of 122°F (50°C) or less.

Voltage Surge Protection

MOV-Capacitor-Resistor networks connected in parallel with each thyristor provide combined voltage surge and dv/dt protection. Thyristor ratings are selected to provide a minimum safety factor of 2.5X the nominal RMS of the AC supply voltage and typical suppressed dv/dt values.

Type of Load

Resistive or inductive loads may be either driven directly, or through an interposing transformer. Three-phase units are designed to drive balanced, three-wire, wye- or delta-connected transformer coupled loads; unbalanced straight resistive loads; or three-phase, 4-wire loads. Special precautions are required to limit peak inrush currents when driving capacitive loads. Consult the factory for application assistance.

Reliability and Performance

Physical Construction

Open panel construction is standard. Units can also be supplied in free standing or wall mounting custom enclosures.

Undervoltage and Phase Loss Protection

The GTU automatically deactivates when VAC falls below approximately 70% of nominal. Normal operation resumes when the line recovers to 80% of AC supply.

Insulation

RMS test voltages; control input circuit @ 500 VAC, power circuit @ 2500 VAC for 208 V through 600 V rated units.

Ambient Temperature Ranges

Operating, 0°F (-20°C) to 122°F (50°C). Consult factory for deratings above 122°F (50°C) or above 6000 ft. elevations.



1 PCI 25-60 amps



1 PCI 90-120 amps



1 PCI 180-225 amps



1 PCI 350-500 amps



1 PCI 650 amps



1 PCI 800-1200 amps

Features

AC Supply

All units rated for nominal value VAC \pm 10%. Standard voltage ratings: 120, 208, 240, 277, 380, 415, 480 and 600 V.

Response Time

Equivalent time constant (63% response) is approximately 50 milliseconds, independent of control input impedance. The maximum rate of output increase can be limited by a "soft start" circuit.

Fuse Protection

The PCI series controllers are available in both fused and fuseless designs. The fused units have I²t coordinated current limiting type fuses. When controlling a transformer primary, the fuseless units utilize electronic overload protection. Consult the factory for the correct SCR current rating for fuseless applications.

Control Inputs

Standard input signals from temperature controllers or PLCs control the PCI series. A listing is provided with the selection guide.

Gain and Bias Controls

The gain and bias controls are conveniently accessed through the front panel for calibration.

Current Limiting

The linear current limit acts to prevent output current from exceeding a preset setpoint even though load resistance may be less than that defined by the ratio of maximum output voltage to rated output current. Cold load inrush currents may be 10X to 20X rated current until high temperature elements come up to heat. Setpoint range is 0 to 150% of rated current. (Note: For three phase units, the GTU auctions the feedback current signals to the maximum of the three line currents. The other two line currents will be less than or equal to the current in the controlled line.)

Overcurrent Trip with Automatic or Remote Manual Reset

A high speed electronic overload trip or chop-off limiter protects the semiconductors against any load shorts. The overcurrent trip monitors the output by means of current transformer feedback. Within a half-cycle that the load fault occurs, the controller automatically shuts off the SCRs. In the instantaneous trip mode, the on-board relay changes state, but will reset after approximately 100 milliseconds. In reclosing operations, three attempts will be made, after which the on-board relay latches. Reset is accomplished by interrupting power or by a remote reset. (See Current Imbalance Detector Option.)

Soft Start Ramp Characteristic

The increasing rate of the output voltage RMS value is limited to prevent high inrush currents with transformer-coupled loads or with elements having high cold-to-hot resistance ratios. With nominal gain setting, rate of increase is limited to approximately 100% per second. Additional protective circuits prevent excessive output bursts due to the fluctuations of reapplied AC supply voltage. Standard ramp time is one second. Optional ramp times are available.

Features

- Conservative thermal design increases service life and minimizes maintenance
- Compact design
- Electrically isolated heat sinks, 25-225 amp units
- Infinite firing-angle resolution for precise control
- SCRs rated 1400 PIV
- I²t fuses, MOVs and dv/dt networks protect SCRs
- Voltage regulated (current/power available)
- Power linear
- Two-year warranty
- CSA Certification and UL Listing pending
- Up-front mechanical design permitting ease of accessibility to all major components
- Programmable logic in GTU eliminates phase sequence sensitivity on three phase units
- Voltage regulation of 0.5% for $\pm 10\%$ nominal line variation
- Current limit and overcurrent trip are standard features
- Soft start



3 PCI 25-225 amps



3 PCI 350-500 amps



3 PCI 650 amps



3 PCI 800-1200 amps

Options

SCR Failure Detector Option

This device senses a shorted SCR and provides a set of form-C relay contacts that the customer may use to alarm and/or turn off the process. The detector is a panel-mount unit that can be supplied for single and three phase applications.

Power Regulation Option

Power regulation compares the feedback and control signals so the output power will be linear to the control signal and will be regulated to maintain a selected constant power level at the controller output despite line and load changes.

Current Imbalance Detector Option

The current imbalance detector continuously compares the load currents of each phase. When an imbalance exceeds a predetermined value of 5 to 50%, a set of form-C contacts may be used to alarm and/or turn off the process. The current limit operated independently. (See Current Limiting.) When selecting the CID option the overcurrent trip option is not included.

Current Regulation (Three Phase)

Regulates SCR current output as a function of control signal input.

Enclosures

The SCRs can be supplied in NEMA enclosures (vented or fan cooled).

SCR Failure Detector

(This option is remotely mounted.) Contact factory or representative for ordering information.

Formulas

- Calculation for three phase current when the line voltage and kW are known:
$$I \text{ (current)} = \text{Power kW} / (\text{Voltage (E)} \times \sqrt{3})$$

example: 60 amps = 50 kW / (480 volts X 1.732)
- Calculation for single phase current when the line voltage and kW are known:
$$I \text{ (current)} = \text{Power kW} / \text{Voltage (E)}$$

example: 104 amps = 50 kW / 480 volts
- Calculation for the heat generated by an SCR controller:
$$(1.5 \text{ volts}) \times (\text{the full load current}) \times (\text{the number of controlled legs}) = \text{total watts}$$

example: 1.5 volts X 60 amps X 3 = 270 watts

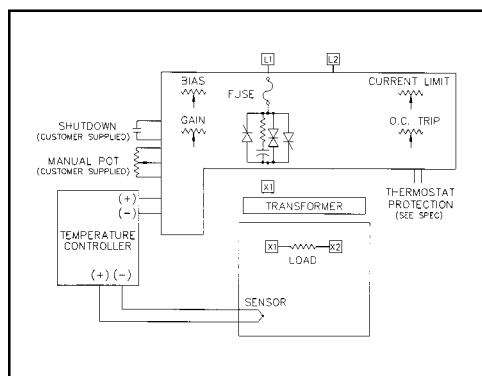

Typical Input/Output Connections for the 1 PCI

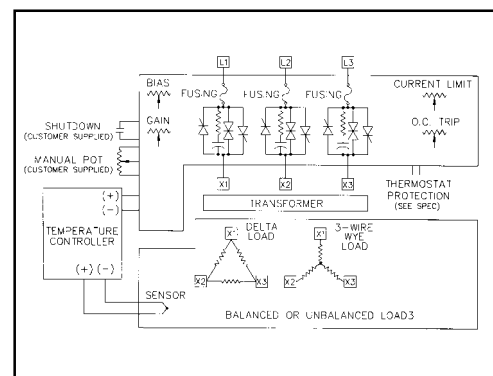

Typical Input/Output Connections for the 3 PCI

Technical Specifications

INPUT LINE VOLTAGE:*	120, 208, 240, 380, 415, 480 or 600 VAC, $\pm 10\%$; 50/60 Hz (± 1 Hz).
CURRENT RATING:*	25, 40, 60, 90, 120, 180, 225, 350, 500, 650, 800, 1000, 1200 amperes.
CONTROL METHODS:**	1) temperature or process controller 2) potentiometer; 5000 ohms, $\frac{1}{2}$ watt (customer supplied) 3) dry contact closure (customer supplied)
CONTROL SIGNAL ISOLATION:	From SCRs—2500 VAC. From AC power input lines—2500 VAC. From chassis — 500 VAC.
VOLTAGE REGULATION:	0.5% per $\pm 10\%$ line voltage change.
LINEARITY:	$\pm 2\%$ FS.
POWER SCR PROTECTION:	1) Subcycle I ² t semiconductor fuse. 2) Transient voltage spikes (dv/dt) across each SCR pair; all SCRs have 1400 PIV rating.
CONTROLS:	BIAS and GAIN potentiometers
AMBIENT TEMPERATURE RANGE:	Operation—max. 122°F (50°C). Storage—14°F to 158°F (-10°C to 70°C).

* Specify with order.

** Specify output when using a temperature/process controller.

1 PCI Series

Amp Range	Dimensions			Weight		Fan Cooling Power (as applicable)	
	Height	Width	Depth*	Lbs.	Kg.	50 Hz	60 Hz
25–60	11.00	8.125	7.625	16.5	7.5	NA	NA
90–120	9.00	9	9.062	16.5	7.5	NA	NA
180–225	16.69	9.44	9.31	20	9.1	0.21 amps, 25 VA	0.19 amps, 23 VA
350–500	21.00	14.25	7.88	24	10.6	0.21 amps, 25 VA	0.19 amps, 23 VA
650	24.00	16.75	12.00	47	21.4	1.40 amps, 168 VA	1.20 amps, 144 VA
800–1200	33.00	16.75	14.50	71	32.3	1.40 amps, 168 VA	1.20 amps, 144 VA

*Lug kits will increase the depth of the 350-1200A units.

3 PCI Series

Amp Range	Dimensions			Weight		Fan Cooling Power (as applicable)	
	Height	Width	Depth*	Lbs.	Kg.	50 Hz	60 Hz
25–60	14.75	19	9.25	40	18.2	NA	NA
90–225	14.75	19	9.25	40	18.2	0.42 amps, 50 VA	0.38 amps, 46 VA
350–500	30.75	19	8.50	60	27.3	0.63 amps, 76 VA	0.57 amps, 69 VA
650	36.00	24	12.00	126	57.3	4.20 amps, 504 VA	3.60 amps, 432 VA
800–1200	42.00	27	14.50	231	105.0	4.20 amps, 504 VA	3.60 amps, 432 VA

*Lug kits will increase the depth of the 350-1200A units.

PCI Series Model Number Configuration

_____	PCI -	_____	-	_____	- CL/OC-D -	_____	-	_____	-	_____	
Phase		Voltage		Amperage		Input		Options		Ramp	Lug Kit

P C I S E R I E S											
Phase		Amperage				Input		Options			
1	Single	25	Amps	-1	0-5 mA	-PR	Power Regulation (remote item in 3 phase)				
		40	Amps	-2	0-20 mA	-CID *	Current Imbalance Detection (remote item)				
3	Three	60	Amps	-3	0-50 mA	-CR	Current Regulation				
		90	Amps	-4	1-5 mA						
		120	Amps	-5	4-20 mA						
		180	Amps	-6	12-20 mA						
		225	Amps	-7	0-5 volts DC						
		350	Amps	-8	0-10 volts DC						
		500	Amps	-9	Potentiometer						
		650	Amps								
		800	Amps								
		1000	Amps								
		1200	Amps								
Voltage						RAMP		Lug Kits			
12	120 Volts					-FR	.47 sec	-LK	If lugs are required for 350 through 1200 amp units.		
20	208 Volts					-ER	4 sec		Lugs are standard for 60-225 amp units		
24	240 Volts										
27	277 Volts										
38	380 Volts (1phase)										
40	400 Volts (3 phase)										
41	415 Volts (1phase)										
48	480 Volts										
60	600 Volts										

All fan cooled units are equipped with "normally open" heat sink thermostats.
"Normally closed" are available upon request.

The table above will assist you in ordering the PCI Series.

For example, for a single phase power controller that was 480 volts, 120 amps, 4-20ma, with a power regulation option, extended ramp, and no lug kit is necessary the model number is:

1PCI-48120-CL/OC-D-5-PR-ER