

CONTROL CONCEPTS INC.

INSTRUCTION MANUAL MODEL 3629C

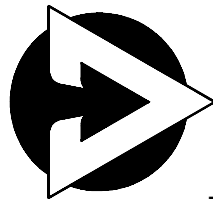

***CONTROL
CONCEPTS***

Distributed Worldwide By
www.mcgooff-bethune.com
Email: sales@mcgooff-bethune.com
1-800-303-4705
+1-770-840-9811

Model 3629C Table of Contents

Description	1
Features	1
Theory of operation	3
Specifications	4
Installation	6
Adjustments	7
Command signal connections	9
Metering connections	12
Installation drawings	13
Line and load connections	18
Troubleshooting	21
Replacement parts list	23
Model Number Identification	24



50 to 750 AMPS

LISTED 3L32 FILE No: E136219
INDUSTRIAL CONTROL EQUIPMENT

NOTE: THE 1000 AMP UNIT IS NOT UL LISTED.

DESCRIPTION:

The model 3629C is a phase-angle SCR controller which linearly controls, with respect to a command signal, the voltage applied to a three phase electrical load. The controller can be connected either *in-line* or *inside delta* configuration. (See figures 6, 24 & 25.)

The 3629C can be configured to control a 4 wire wye load or with the addition of a 3-phase bridge can control a DC load. (See figures 6, 26 & 27.)

The 3629C controller can accept a 0 to 5Vdc command signal or a potentiometer control. The controller may also be configured to accept a 4/20mA current loop or a 0-10Vdc command signal. (See figure 6.)

The command signal input terminals are electrically isolated from the line and load voltages.

The line and load voltages are isolated from the heatsink on the 50, 80, 120 and 160 Amp units.

FEATURES:

- 1. RMS Current Limit**, sets the maximum load current to a desired value. The circuit senses the highest current on the three loads. This feature is useful for variable resistance loads, or loads that have a low resistance when cold.
- 2. Current Limit Metering**, contacts on the command connector ease the calibration of the current limit setting. (See Page 12.)
- 3. Over Current Trip**, latches the controller off until reset, energizes a relay with form "C" contacts and lights an LED if the load current exceeds a preset value.
These contacts, available on the command connector, may be used to operate an alarm or other devices.
(Contacts are rated 250 Volts at 5 Amps.)
- 4. Over Current Trip Setting**, allows independent adjustment of the over current trip point. Factory set at 175%.
- 5. Over Current Trip Metering**, contacts on the command connector ease the calibration of the O.C.T. feature. (See Page 12.)
- 6. Top adjust pots**, make it possible to calibrate the controller without the necessity of removing the lid.
- 7. 60 Degree Gate Drive**, provides stable operation of the SCR's.
- 8. A shorted SCR detector**, lights an LED and energizes a relay with form "C" contacts if an SCR fails in the shorted mode. These contacts, with connections available on the command connector, may be used to operate an alarm.
(Contacts are rated 250 Volts at 5 Amps.)
- 9. Auto Phase Rotation Sensing**, The controller is not phase rotation sensitive.
- 10. Missing cycle detection**, if the power is momentarily interrupted, the load voltage is set to zero and then increased to the desired value at a rate equal to a time constant of approximately 0.2 seconds when power is reapplied.
- 11. Soft start**, causes the controller to increase power to the desired value at a rate equal to a time constant of approximately 0.2 seconds.
- 12. Transient protection**, a snubber circuit consisting of a non-inductive resistor in series with a capacitor, is connected in parallel with each SCR pair to protect against high frequency transients. An MOV (metal oxide varistor) is also connected across each SCR pair to protect against high voltage transients.
- 13. Choice of Feedback**,
 - A. RMS Voltage feedback** (internal) allows the RMS value of the load voltage, to be linear with respect to the command signal.
 - B. Average voltage feedback**, (factory installed option) allows the average value of the load voltage to be linear with respect to the command signal. Average voltage feedback is most often used for DC applications.
 - C. External feedback**, may also be selected. See Figure 11 on page 11. Contact the Control Concepts factory with questions about your application.

(Features continued on next page.)

FEATURES: (Continued.)

- 14. Connection for a remote reset switch,** which, if momentarily closed, resets the Over Current Trip relay and resets the circuit to allow the load voltage to ramp from zero to the desired value.
The switch can also be used to provide remote "on-off" control. Closure of the switch immediately interrupts the SCR operation and removes load voltage.
See Fig. 13 on page 11.
- 15. Eight status indicators** provide the following information:
- A. "COMMAND INDICATOR" LED,** the intensity of which, is proportional to the command signal.
 - B. "LINE C" LED's,** the intensity of which, is proportional to the magnitude of the line 3 load current.
 - C. "LINE B" LED's,** the intensity of which, is proportional to the magnitude of the line 2 load current.
 - D. "LINE A" LED's,** the intensity of which, is proportional to the magnitude of the line 1 load current.
 - E. "LINE-OK" LED** when on, indicates that all three phases are applied.
 - F. "SHORTED SCR" LED,** when on, indicates that an SCR has failed in the shorted mode or is repeatedly missfiring.
 - G. "OVER CURRENT" LED,** when on, indicates that the over current trip point has been reached and the SCRs are de-energized.
 - H. "CURRENT LIMIT" LED,** when on, indicates that the load current has reached the current limit setting and cannot be increased by raising the command signal.
- 16. Controller Ready Signal,** is available on the command connector. (See Fig.9.)
When this signal remains high, it indicates one or more of the following events have occurred:
- A. Over current.**
 - B. One or more of the line phases is not present.**
 - C. One or more phases are not present on the firing circuit board.**
(Circuit fuse may be cleared.)
 - D. The phase lock is not enabled.**
 - E. The gate drive is not enabled.**
 - F. The Over Current Trip reset switch may be closed.**
- 17. Choice of Command Signal,**
(See Figs. 7 & 8)
- A. 0 to +5 Volts DC.**
 - B. Potentiometer. 1 Kohm to 20 Kohms.**
 - C. Placing a jumper across the pins on JP1,** allows the controller to accept a command signal of 0 to +10 Volts DC.
 - D. By replacing one resistor,** the controller may be configured to accept a 4 to 20mA current loop command signal. (See Fig. 6 on page 8)
- 18. Operating Modes.**
The model 3629C was designed to offer four user selectable operating modes.
A switch on the circuit board allows the operator to select the desired mode.
See figure 6 on page 8.
Unless ordered otherwise, the controller is shipped with the switch in the in-line mode.
- IN-LINE.** This is an ideal configuration for inductive loads, unbalanced resistive loads and transformer coupled loads.
See Figures 24, 28 & 29 on pages 18 & 20.
- INSIDE DELTA.** Three phase inside delta control is basically three single phase controllers on the same frame that are operating from the same command signal.
3629C controllers incorporate SCR's with higher PIV ratings to accommodate the voltages encountered in an inside delta configuration.
See Figure 25 on page 18.
- SIX SCR DC.** As the name implies, this mode is made to drive a three-phase diode bridge to provide power for many applications requiring a variable DC source. The gate drive is limited to 120 degrees for this mode. (This is full on for a DC controller.)
See figure 26 on page 19.
- 4-WIRE WYE.** When powering a WYE load, it is desirable to use the 4-wire configuration to reduce voltage surges due to open loads. These open load surges could destroy an SCR. See figure 27 on page 19.

THEORY OF OPERATION:

THE SCR

The heart of the SCR power controller is the SCR (silicon controlled rectifier, also sometimes referred to as a thyristor).

The SCR has two states, ON and OFF, and allows current to flow in only one direction when turned on. SCRs can remain in the off state even though the applied potential may be several thousand volts. In the on state, they can pass several thousand amperes. When a small signal is applied between the gate and cathode terminals, the SCR will turn on within 10-100 microseconds. Once turned on, it will remain on until the current through it is reduced below a very low value, referred to as the holding current.

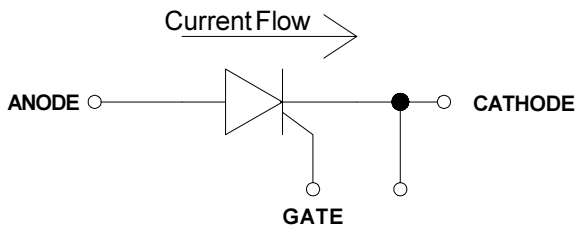

Figure 1. SCR symbol

PHASE-ANGLE OPERATION

In phase-angle control, each SCR of the back-to-back pair is turned on for a variable portion of the half-cycle that it conducts (Figure 4). Power is regulated by advancing or delaying the point at which the SCR is turned ON within each half cycle. Light dimmers are an example of phase-angle control.

Phase-angle control provides a very fine resolution of power and is used to control fast responding loads such as tungsten-filament lamps or loads in which the resistance changes as a function of temperature. Phase-angle control is required if the load is transformer-coupled or inductive.

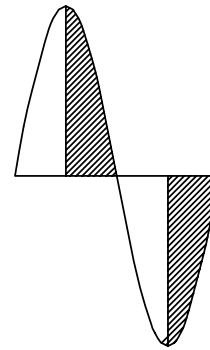

Figure 3. SCR "ON" time, shown by shaded area, is varied to apply the desired load voltage.

Because the SCR allows current to flow in only one direction, two SCR's are connected in an inverse parallel (back to back) configuration to control AC current.

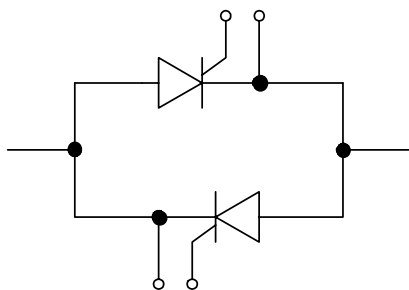

Figure 2. "AC Switch"

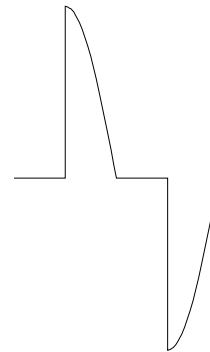

Figure 4. Power is regulated by advancing or delaying the point at which the SCR's are turned on.

What is the difference between Current Limiting and Over Current trip?

Current Limit is a circuit that causes the controller to stop increasing the output voltage when a predetermined current limit setting has been reached. The controller will continue to operate normally up to the current limit setting.

Over Current Trip is a circuit that causes the controller to shut down when a predetermined setting has been reached. No output will be available until the reset has been operated or the power is interrupted.

SPECIFICATIONS:

The following specifications apply over an ambient temperature range of 0 to 55°C and a supply voltage of 85% to 110% of the nominal supply voltage rating.

Control Mode:	Three-phase in line, Three-phase inside delta, 4-wire wye or DC. 6 SCR, phase-angle control of the RMS or average load voltage. External feedback is available. See pages 18, 19 & 20.										
Command Signal:	<table border="0"> <tr> <td>Input signal</td> <td>Input Impedance:</td> </tr> <tr> <td>0-5Vdc</td> <td>200K ohms</td> </tr> <tr> <td>0-10Vdc</td> <td>200K ohms</td> </tr> <tr> <td>Potentiometer</td> <td>200K ohms</td> </tr> <tr> <td>4/20mA</td> <td>300 ohms</td> </tr> </table> <p>A 1K to 20K potentiometer is excited by 5Vdc, supplied by the circuit. Other input signals may be available. Check with factory for special applications.</p>	Input signal	Input Impedance:	0-5Vdc	200K ohms	0-10Vdc	200K ohms	Potentiometer	200K ohms	4/20mA	300 ohms
Input signal	Input Impedance:										
0-5Vdc	200K ohms										
0-10Vdc	200K ohms										
Potentiometer	200K ohms										
4/20mA	300 ohms										
Control Range:	0 to 98% of line voltage.										
Linearity:	Output will be linear within 2% of span over entire range of control.										
Current Limit Range:	Adjustable from 20% to 125% of frame current as specified in the "(Amps)A" term within the model number. If no IL term is specified when ordering, then current limit is factory set to 105% of frame current rating.										
Zero and Span Adjustments:	Multi-turn potentiometers allow zero and span adjustments of $\pm 25\%$ of span.										
Dissipation:	Approximately 1.5 watts per amp of current per phase will be dissipated by the controller.										
Supply Voltage:	208, 240, 380, 415, 480, or 575Vac, 3 phase, @ 50/60 Hertz. Other operating voltages may be available by special order.										
Environment:	Operating temperature 0 to 55°C (32 to 132°F). Storage temperature: -40 to 85°C (-40 to 176°F). Humidity: 0 to 95%, non-condensing.										
Electrical Isolation:	Heat sink to supply and load voltage on units rated 50 to 160 Amps: 2500 volts peak. Command signal to supply and load voltage: 2500 volts peak.										
Status Indicators:	<p>LINE OK: Indicates power on all three phases and phase lock capture OK.</p> <p>COMMAND: The intensity of this LED is proportional to the command signal.</p> <p>LINE A, LINE B, LINE C: The intensity of these three LEDs is proportional to the current in each leg.</p> <p>SHORTED SCR: Indicates when an SCR has failed in the shorted mode.</p> <p>OVER CURRENT: Indicates excessive current has occurred.</p> <p>CURRENT LIMIT: Indicates when unit is in current limit mode.</p>										

SPECIFICATIONS: (continued)

Ready Signal:	An open drain Field Effect Transistor provides a signal which may be used to control an LED, a relay or a logic level shift. This signal will remain high if conditions exist within the controller that prevent the controller from providing a controlled output. See Figure 9 on page 9. Sample circuits on page 10.
Cooling:	Convection cooling on 50 amp unit. Forced air fan cooling on all other models.
SCR Surge Current:	Peak 1 cycle surge current is: 50 Amp rating - 1,750 A Surge 80 Amp rating - 1,750 A Surge 120 Amp rating - 1,900 A Surge 160 Amp rating - 4,000 A Surge 200 Amp rating - 5,200 A Surge 250 Amp rating - 5,200 A Surge 300 Amp rating - 7,000 A Surge 380 Amp rating - 10,000 A Surge 425 Amp rating - 13,000 A Surge 500 Amp rating - 10,000 A Surge 600 Amp rating - 13,000 A Surge 750 Amp rating - 20,000 A Surge 1000 Amp rating - 26,000 A Surge
SCR I²T Rating:	50 Amp rating - 15,000 A ² S 80 Amp rating - 15,000 A ² S 120 Amp rating - 18,000 A ² S 160 Amp rating - 80,000 A ² S 200 Amp rating - 135,000 A ² S 250 Amp rating - 135,000 A ² S 300 Amp rating - 245,000 A ² S 380 Amp rating - 500,000 A ² S 425 Amp rating - 845,000 A ² S 500 Amp rating - 500,000 A ² S 600 Amp rating - 845,000 A ² S 750 Amp rating - 1,670,000 A ² S 1000 Amp rating - 2,815,000 A ² S
SCR Voltage Rating	50-750 Amp Frames: Peak forward and reverse voltage rating 1600V. 1000 Amp Frame: Peak forward and reverse voltage rating 1800V.
SCR DV/DT Rating:	200 volts/usec minimum.
Loads:	Resistive, Variable resistance, Inductive, Capacitive, Transformer or Lamps.
Slew Rate:	200 milli-seconds. (Slew rate is the time required for the load voltage to change 63% of the value represented by the command signal. The current limit action will change the slew rate if the load current is greater than the current rating of the SCRs.
Frame Size:	The "(Amps)A" term within the model number specifies the maximum continuous RMS current rating at the maximum operating ambient temperature of 55°C.

INSTALLATION:

MOUNTING:

The 50 Amp model 3629C controller is convection cooled and must be mounted with the fins aligned vertically on a flat surface so that air may pass over the fins.

Although larger model 3629C controllers are forced air cooled, it is recommended that all controllers be mounted vertically with power terminals on top.

Allow at least 3" of space between controllers for air to enter and exit. The controller should be protected from dust and dirt, and must be located in an environment that does not exceed 55°C.

TRANSFORMER TAPS:

If the line voltage input is to be changed, place the three faston connectors on the transformer taps to correspond with the voltage to be applied.

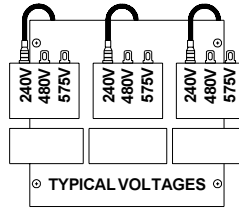

NOTE: The transformer may fail if all three of the connections to the taps are not correctly placed. All faston connectors must be moved to the same corresponding voltage tab on each phase as shown in the sample illustration.

POWER CONNECTIONS:

The line and load connectors on the various sizes of controllers are rated for use with copper conductors with 90°C or higher insulation. The ratings are calculated for use in a 55°C ambient environment. Multiple connectors are provided in larger controllers to use parallel conductors in each line and load.

See Fig. 24 and Fig 25 on page 18 for the 'inline' and 'inside delta' line and load connections.

COMMAND CONNECTIONS:

Figures 7 & 8 on page 9 show the command signal connections.

Note that R47 must equal 300ohms when applying a 4/20mA current command signal. (For location of R47, see Fig. 6 on page 8.)

STARTUP:

Before applying power, determine that the transformer taps are in the correct positions, that the power and load wiring is correct, and electrical connections are tight.

Set the command to zero and apply power to the controller. As the command signal is increased, the load voltage should start at zero and increase.

It is recommended that the load and the controller be protected with the proper rated fuses. See page 23 for details.

WIRE TERMINAL TORQUE RECOMMENDATIONS

TO AVOID FIRE OR DAMAGE TO EQUIPMENT, DETERMINE THAT WIRE CONNECTIONS ARE TIGHTENED TO THE TORQUE SPECIFICATIONS BELOW AND THE CONNECTION SURFACES ARE FREE OF OXIDATION.

FRAME SIZE 50 & 80 AMPS

GAUGE	INCH-LBS
14 to 10 ga	35
8 ga	40
6 to 4 ga	45
3 to 2 ga	50

FRAME SIZE 120 TO 1000 AMPS

WIRE SIZE	INCH-LBS
6 to 4 ga	100
2 to 1 ga	125
1/0 to 2/0	150
4/0 to 3/0	200
250 to 350 MCM	250
500MCM	300

USING TRANSFORMER COUPLED LOADS

SCOTT-T TRANSFORMERS

Excessive voltage transients can occur when operating Scott-T transformers with an open or unloaded secondary.

It is recommended that Scott-T transformer applications be limited to 480 Volts maximum.

DELTA-WYE TRANSFORMERS

It is recommended that a Delta to 4-wire Wye transformer be used to power a 4-wire Wye load.

Delta to 3-wire Wye transformers are acceptable, but Wye to Wye transformers are not suited for use between the controller and load due to transient conditions which may occur.

Please consult factory if you have questions regarding your application.

ADJUSTMENTS:

The zero and span potentiometers are factory set, and generally do not require further adjustment.

If adjustments become necessary, the following procedure should be followed.

If you are using RMS feedback, you must use a true RMS meter for these measurements.

1. Set the command signal to minimum and adjust the zero potentiometer until the output is zero. If this pot is set incorrectly, the output of the controller may not be linear with respect to the command signal, or, the controller may be unable to shut off completely.
2. Set the command signal to maximum and adjust the span potentiometer until the output is at the desired maximum value. If this pot is set incorrectly, the output of the controller may not be linear with respect to the command signal, or, the controller may be unable to reach full output.
3. The span and zero adjustments may interact, therefore it may be necessary to repeat steps 1 and 2.

Current limit potentiometer adjustment.

To monitor the Current Limit Adjustment, apply the negative lead of your multimeter to terminal 14 of the command connector, and the positive lead to terminal 17. See figure 15 on page 12.

Rotating the Current Limit potentiometer clockwise increases the value to which the load current is limited. Negative 1Volt = 100% of frame current.

Over Current Trip potentiometer adjustment.

To monitor the Over Current trip Adjustment, apply the negative lead of your multimeter to terminal 14 of the command connector, and the positive lead to terminal 18. See figure 14 on page 12.

Rotating the Over Current Trip potentiometer clockwise increases the value at which the Over Current Trip circuit will activate. Positive 1Volt = 100% of frame current.

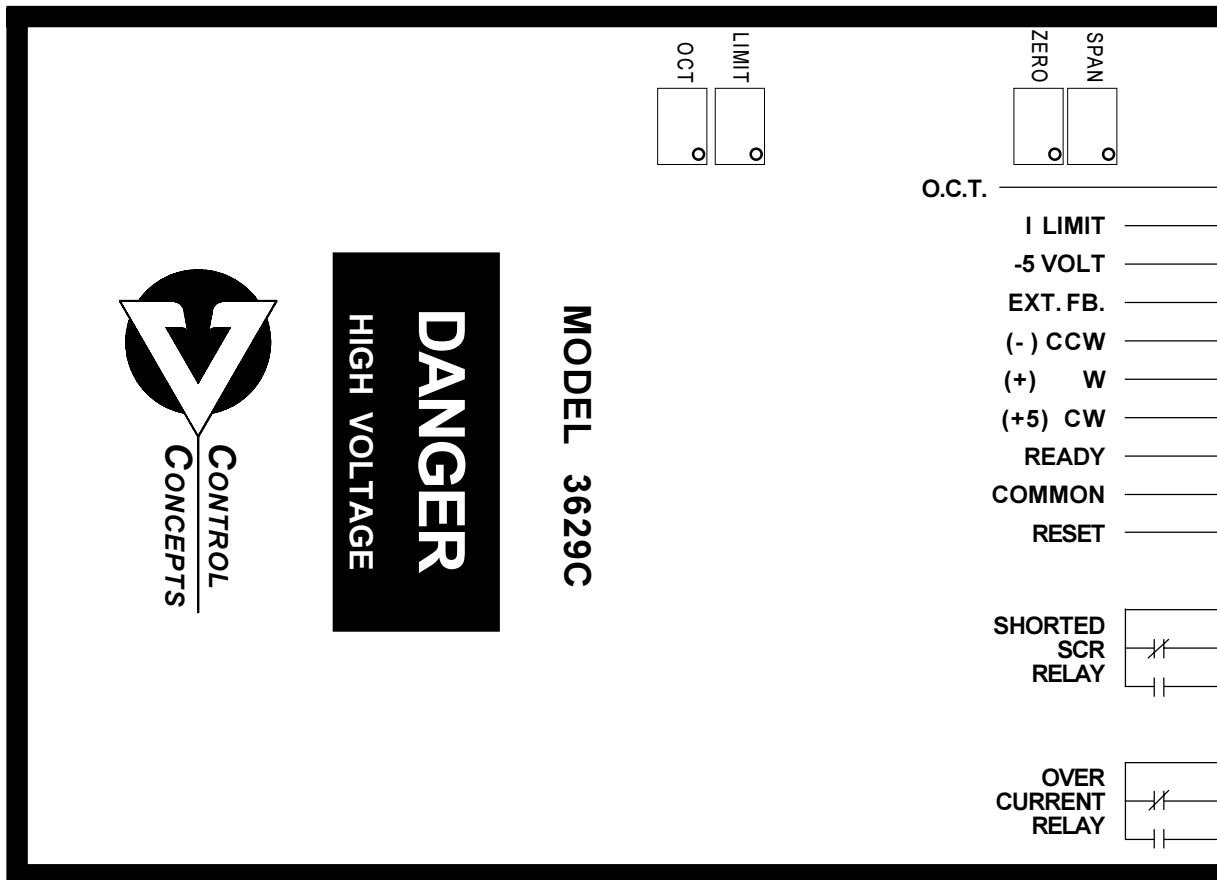
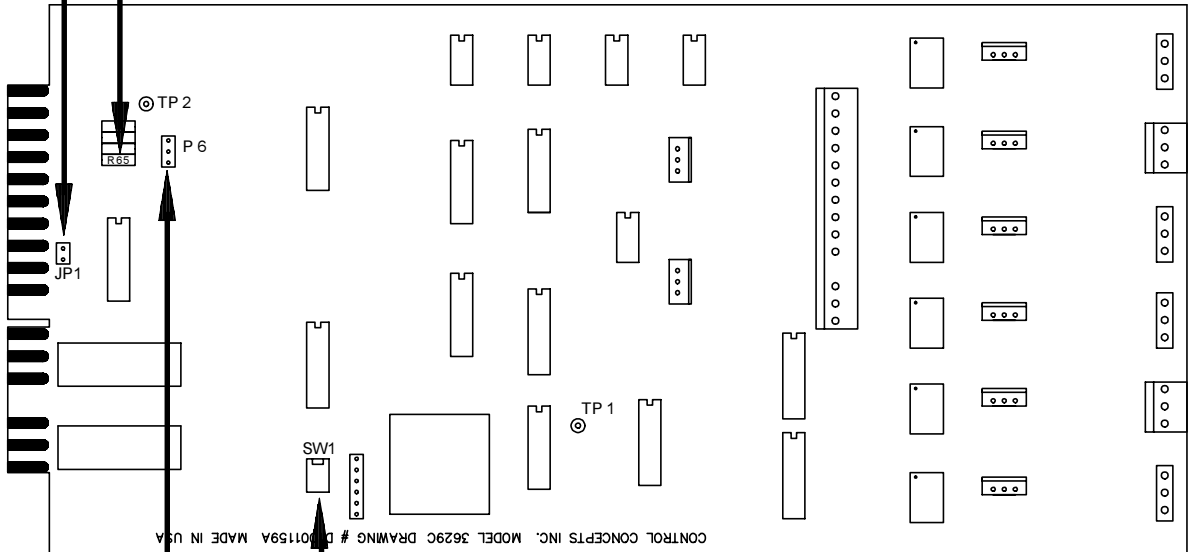

Figure 5. Lid of 3629C showing the adjustment locations.

ADJUSTMENTS: (Continued)

Place a jumper across pins 1 & 2 on JP1 when you desire to use a 0 to 10 Vdc signal. No jumper for all other command signals.

A 300 ohm resistor must be added in the R65 position when you use a 4/20mA command signal. Contact factory for more information.



Mode Switch (SW1, SW2)

	MODE	SW1	SW2
	SCR INLINE	X	X
	INSIDE DELTA	O	X
	6 SCR DC	X	O
	4 WIRE WYE	O	O

O = OPEN, X = CLOSED

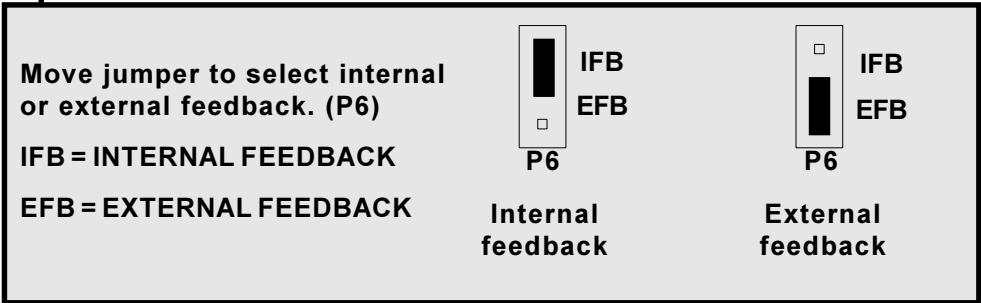

Figure 6. User adjustable components on circuit board.

COMMAND CONNECTOR WIRING

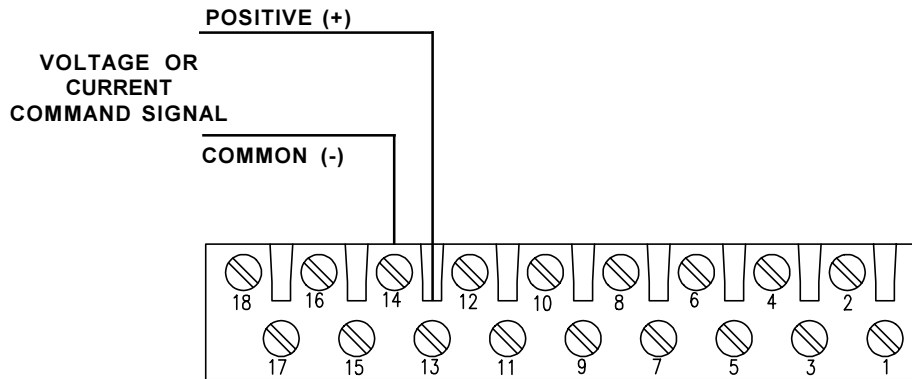

Figure 7. Voltage or current command connections.

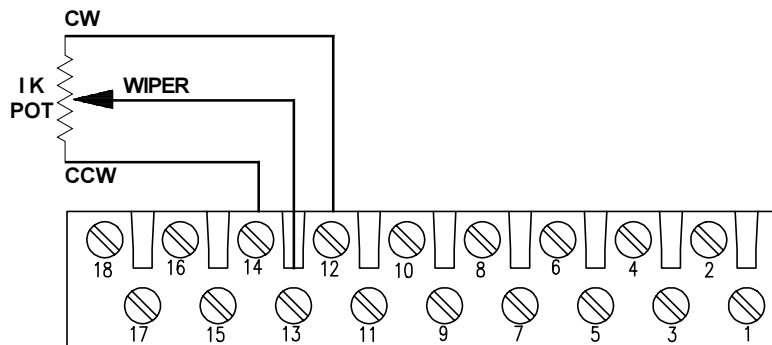

Figure 8. Potentiometer command connections.

The **Controller Ready** signal is controlled by an open collector transistor which will go high when pulled up by an external circuit. Any of the conditions listed below will prevent the ready signal from going low.

- Over current.
- One or more of the line phases is not present.
- One or more phases are not present on the firing circuit board. (Circuit fuse may be cleared.)
- The phase lock is not enabled.
- The gate drive is not enabled.
- The Over Current Trip reset switch may be closed.

See sample circuits on page 10.

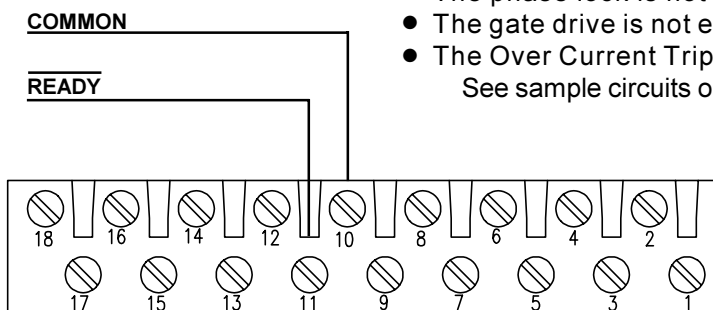

Figure 9. Ready Output.

EXAMPLES OF READY SIGNAL CONNECTIONS:

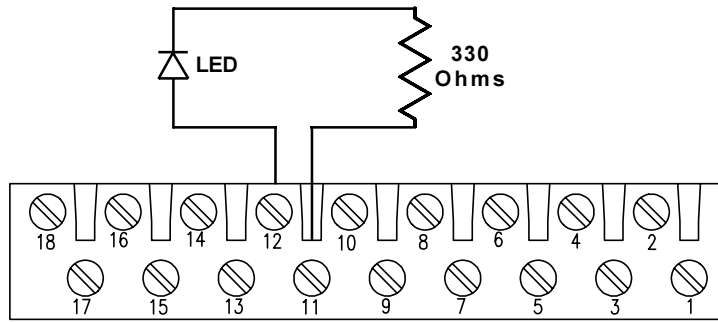

Figure 10A. Sample LED Circuit.

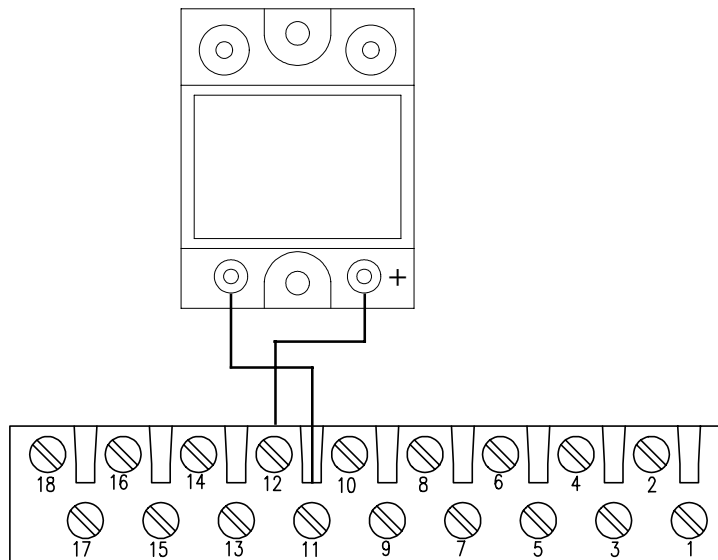

Figure 10B. Sample Solid State Relay Circuit.

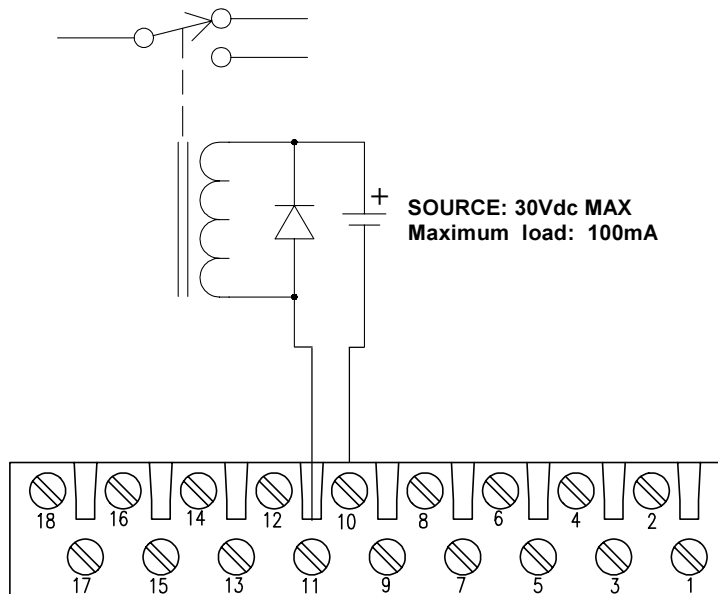

Figure 10C. Sample External Relay w/power supply Circuit.

COMMAND CONNECTOR WIRING

Note: to insure proper operation, isolation of the feedback source may be required. Contact the factory for further information.

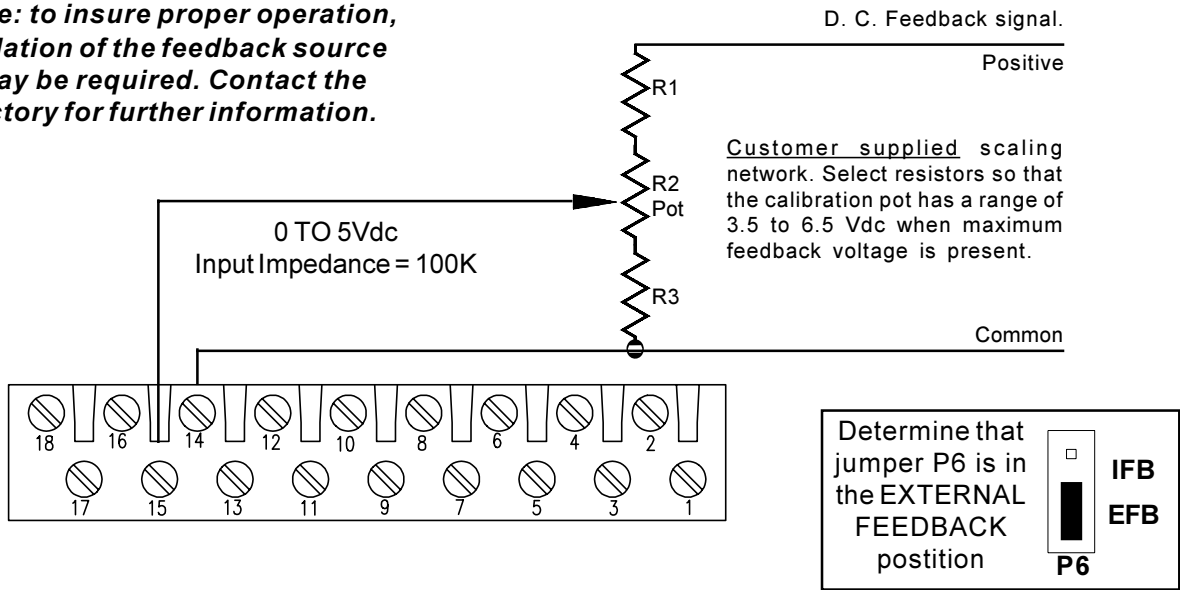

Figure 11. External voltage feedback.

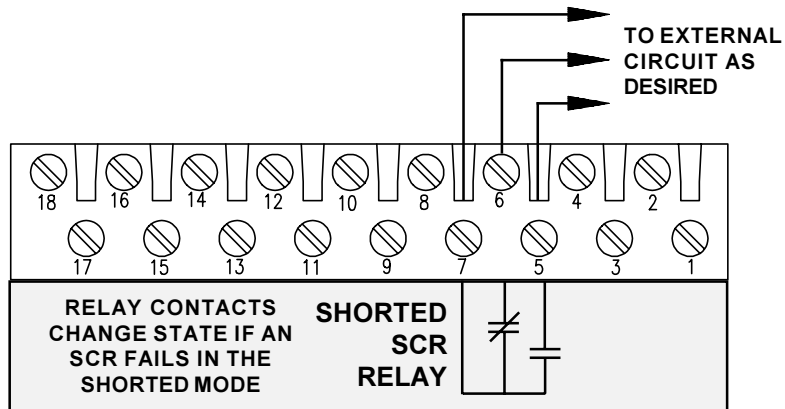

Figure 12. Shorted SCR relay connections.

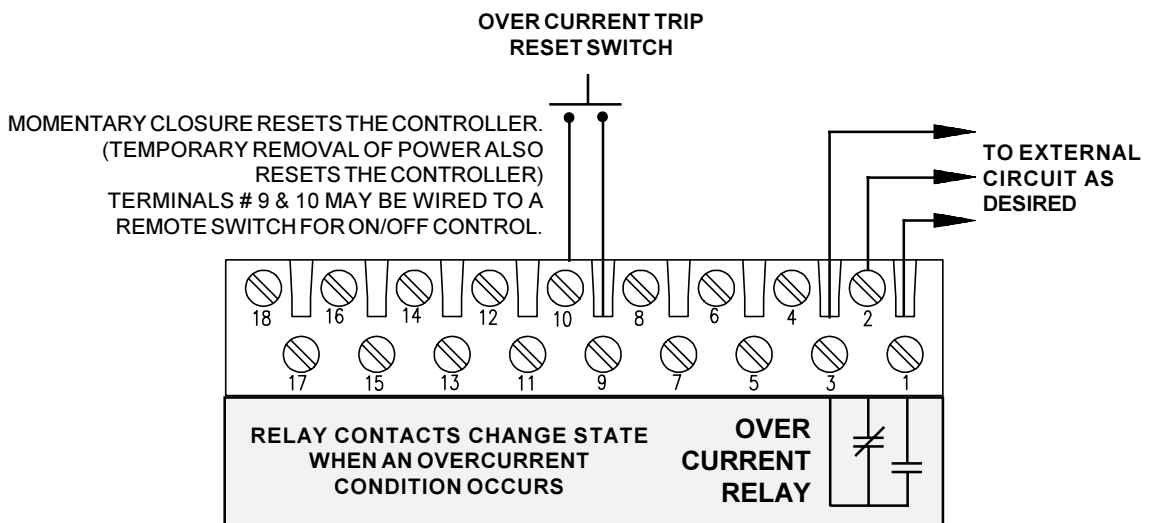

Figure 13. Over current relay and reset switch connections.

METERING OVER CURRENT TRIP & CURRENT LIMIT SETTINGS:

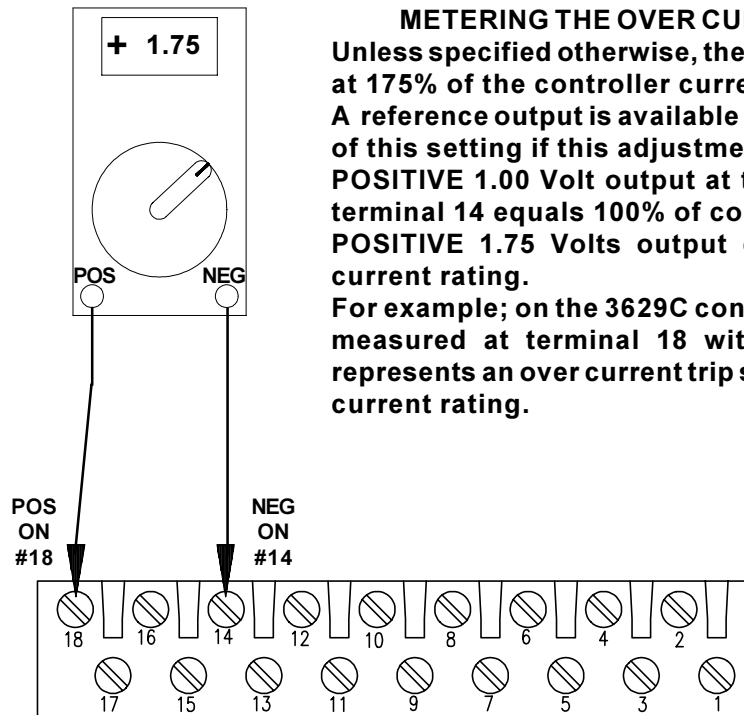

Figure 14. Over Current Trip Metering Output.

METERING THE OVER CURRENT TRIP SETTING.

Unless specified otherwise, the OVER CURRENT TRIP is set at 175% of the controller current rating at the factory.

A reference output is available to assist in the recalibration of this setting if this adjustment is accidentally changed.

POSITIVE 1.00 Volt output at terminal 18 with respect to terminal 14 equals 100% of controller current rating.

POSITIVE 1.75 Volts output equals 175% of controller current rating.

For example; on the 3629C controller, POSITIVE 1.50 volts measured at terminal 18 with respect to terminal 14, represents an over current trip setting of 150% of controller current rating.

METERING THE CURRENT LIMIT SETTING.

Unless specified otherwise, the CURRENT LIMIT is set at 105% of the controller current rating at the factory.

A reference output is available to assist in the recalibration of this setting if this adjustment is accidentally changed.

NEGATIVE 1.00 Volt output at terminal 17 with respect to terminal 14 equals 100% of controller current rating.

NEGATIVE 1.05 Volts output will equal the original 105% setting.

For example; on any 3629C controller, NEGATIVE 1.05 volts measured at terminal 17 represents a current limit setting at 105% of the controller current rating.

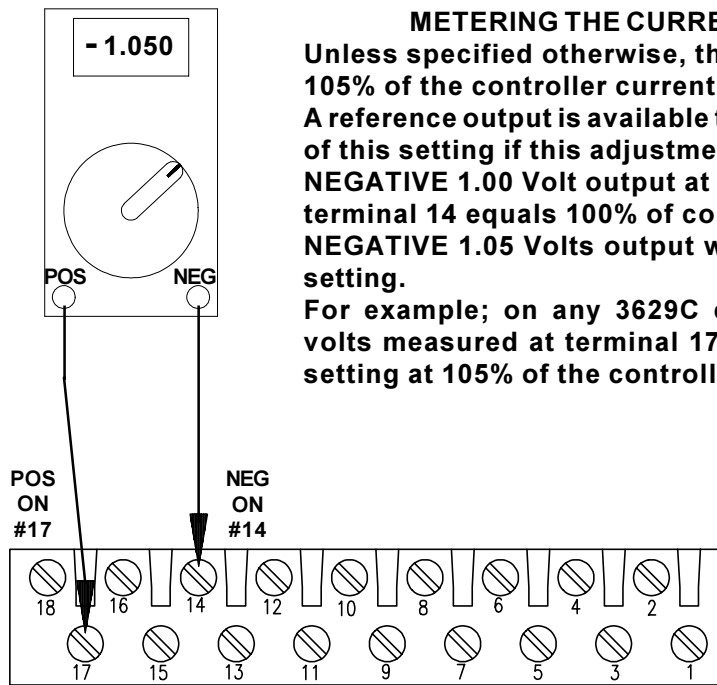
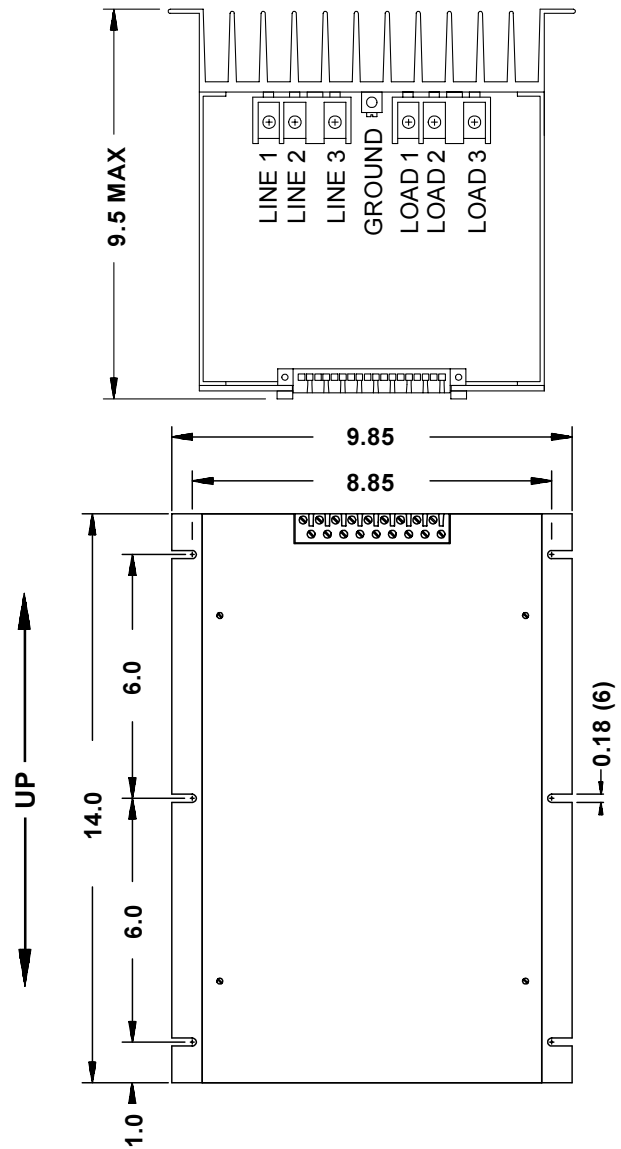

Figure 15. Current Limit Metering Output.

INSTALLATION DRAWINGS:



Note: The 50 amp controller does not have a fan, and requires convection cooling. This unit must be mounted on a vertical panel with the fins oriented vertically, so that air may pass between the cooling fins without restriction. MAINTAIN 3" MINIMUM SPACE BETWEEN CONTROLLERS

Figure 16. 50 Amp model 3629C controller.

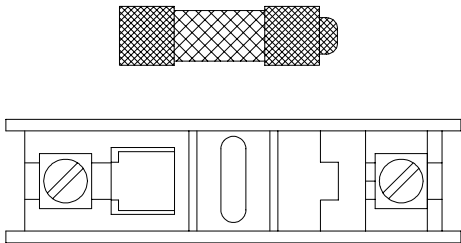

Figure 16A. Orientation of fuse.

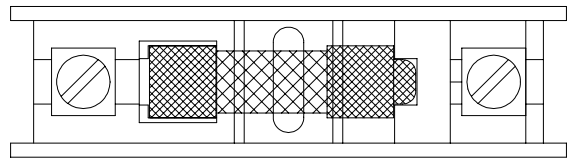

Figure 16B. Fuse installed in fuseholder. Fuse makes contact only when correctly installed.

INSTALLATION DRAWINGS: (Continued)

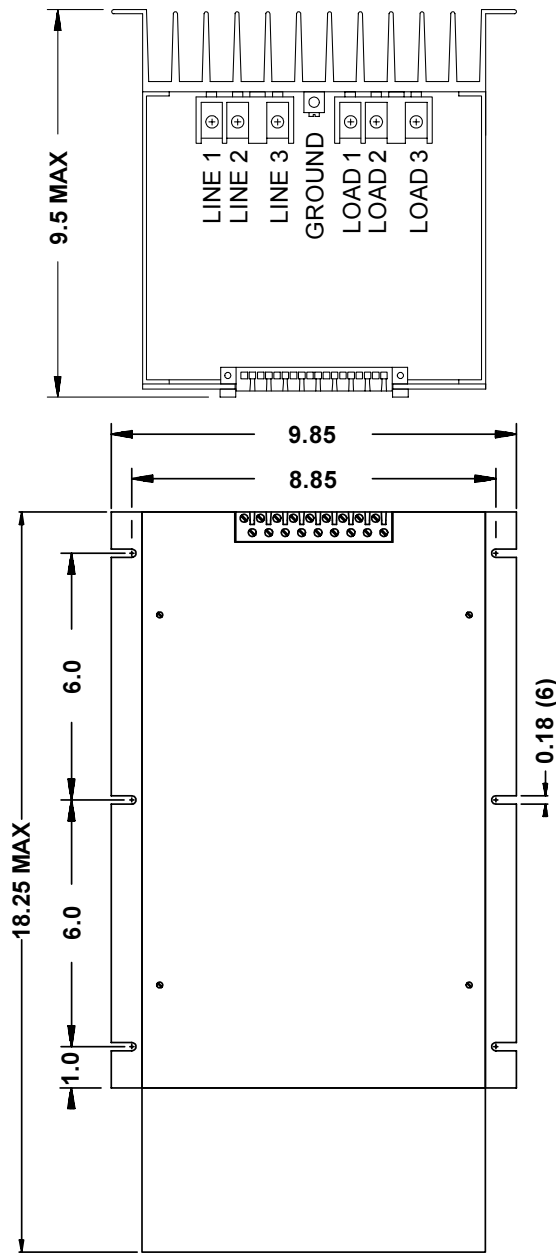

Figure 17. 80 Amp 3629C controller.

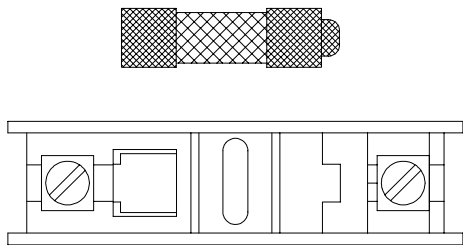

Figure 17a. Orientation of fuse.

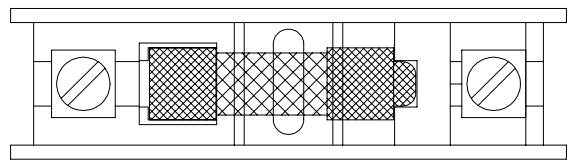

Figure 17b. Fuse installed in fuseholder. Fuse makes contact only when correctly installed.

INSTALLATION DRAWINGS: (Continued)

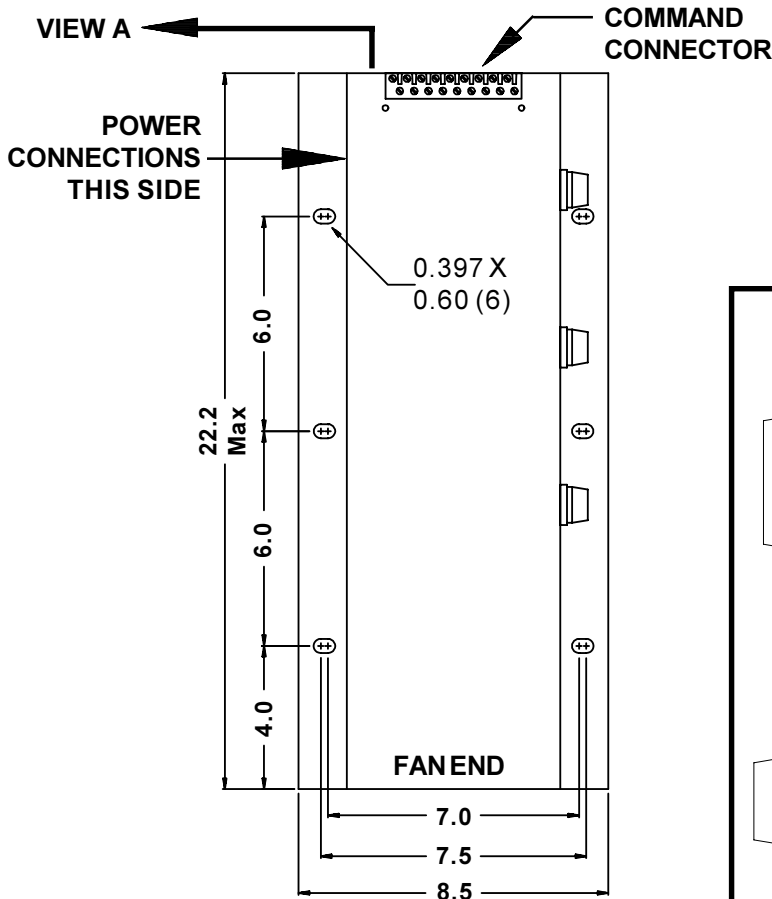

Figure 18. Top view of 120 & 160 amp 3629C controller.

120 & 160 AMP CONTROLLERS ONLY

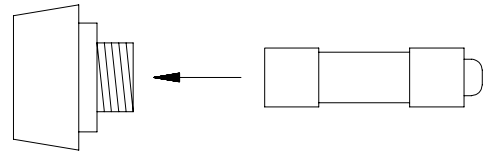

Figure 18A.
Place flat end of fuse in Cap.

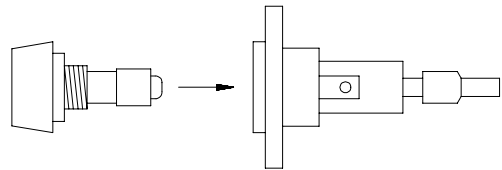

Figure 18B.
Place fuse & cap into fuseholder.
Fuse will not make contact if inserted wrong.

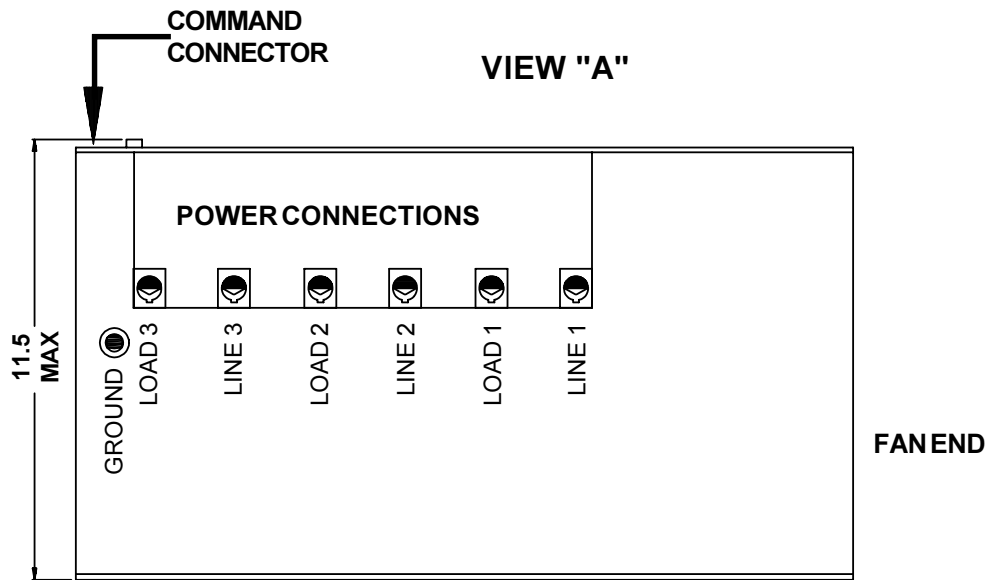

Figure 19. Side view of 120 & 160 amp 3629C controller.

INSTALLATION DRAWINGS: (Continued)

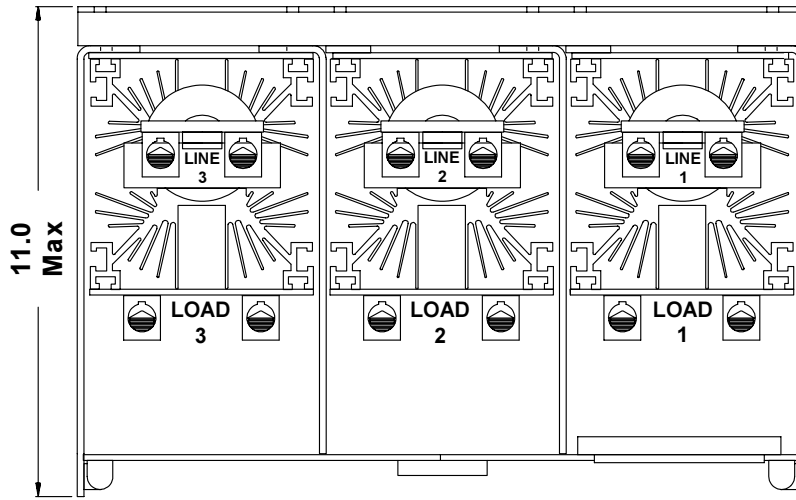

Figure 20. End view of 200 to 425 Amp 3629C controller

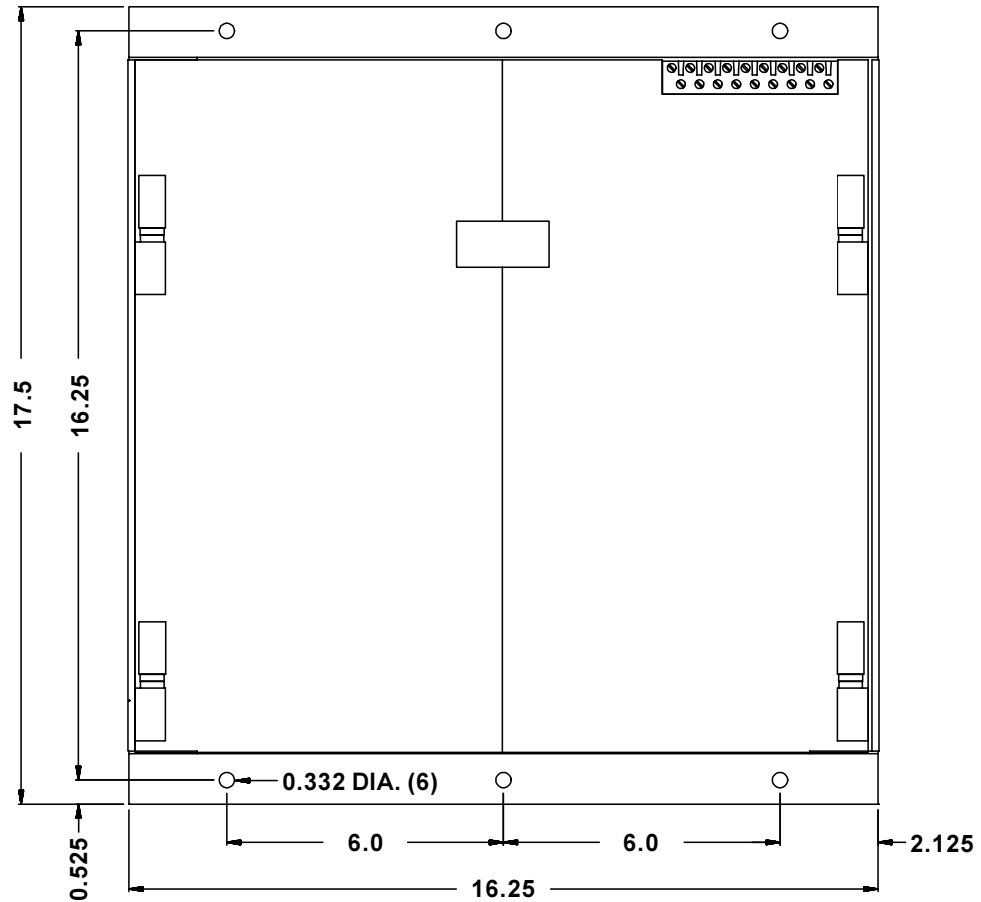

Figure 21. Top view of 200 to 425 Amp 3629C controller.
SEE PAGE 14 or 15 FOR CIRCUIT FUSE ORIENTATION

INSTALLATION DRAWINGS: (Continued)

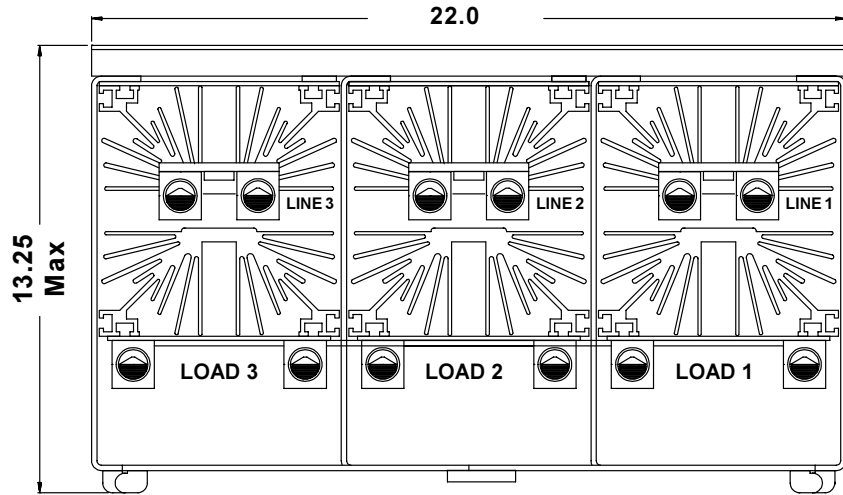

Figure 22. End view of 500 to 1000 Amp 3629C controller
1000 Amp controller has 4 wire lugs per termination.

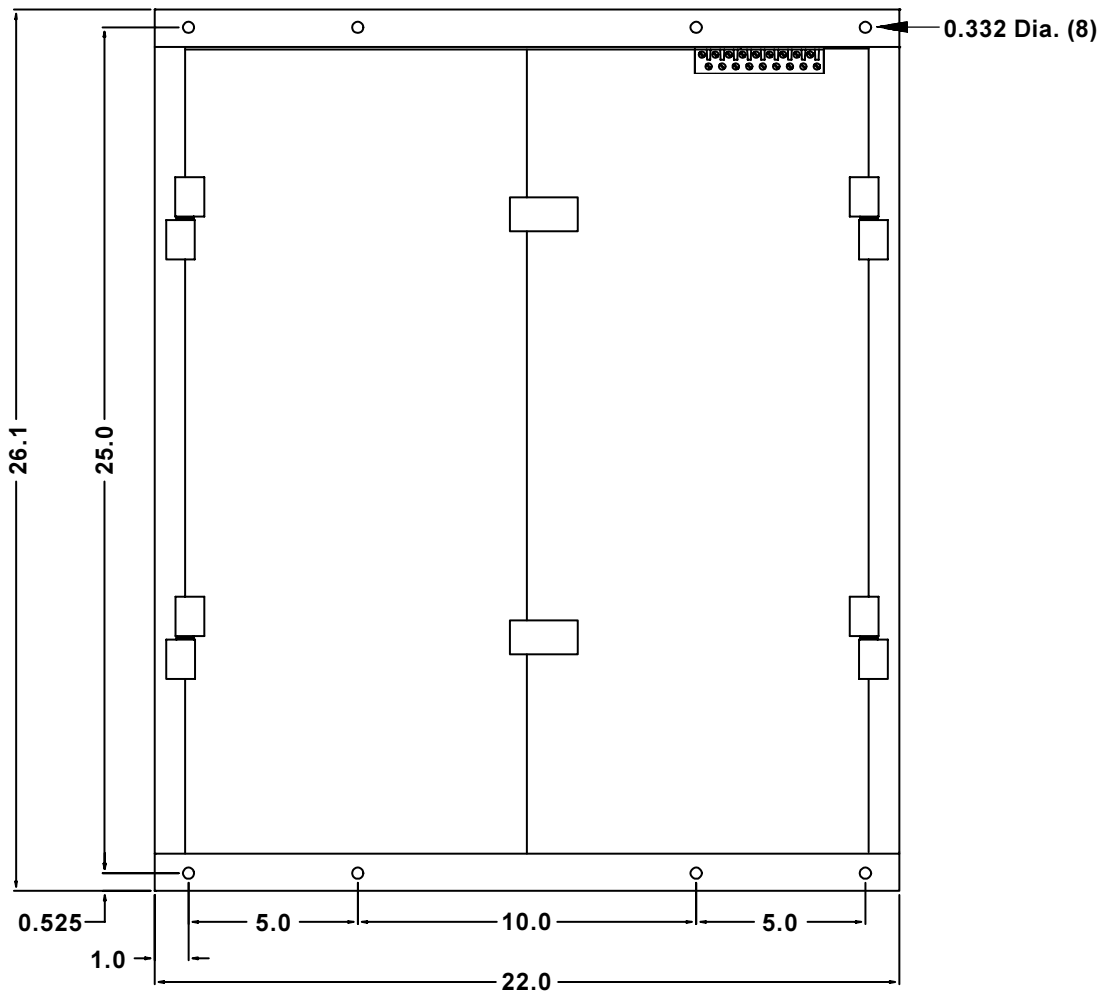
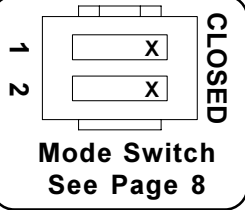

Figure 23. Top view of 500 to 1000 Amp 3629C controller.
SEE PAGE 14 or 15 FOR CIRCUIT FUSE ORIENTATION

ELECTRICAL HOOKUPS:



Note: It is recommended that the load and controller be protected by 3 class "T" or "Semiconductor fuses. Choose a fuse size approximately 120 to 125% of the current rating of the controller. See page 23 for information.

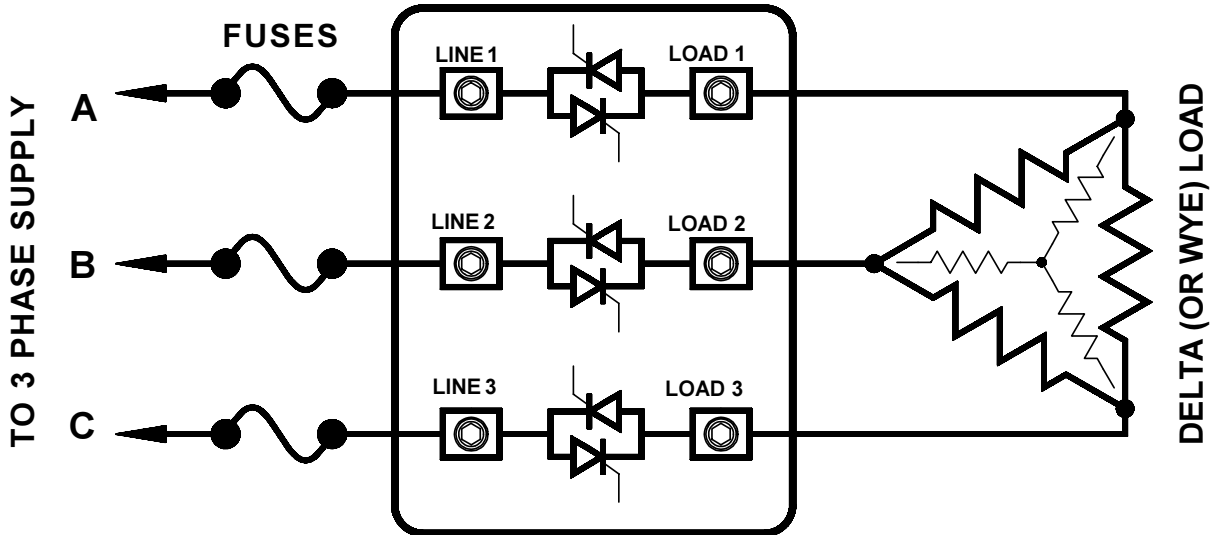
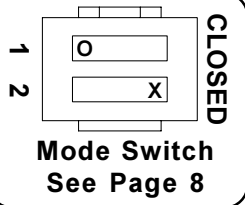

Figure 24. In-line power connections.



Note: Three (3) Power distribution blocks must be provided by customer.

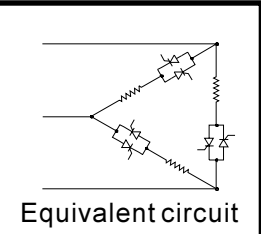
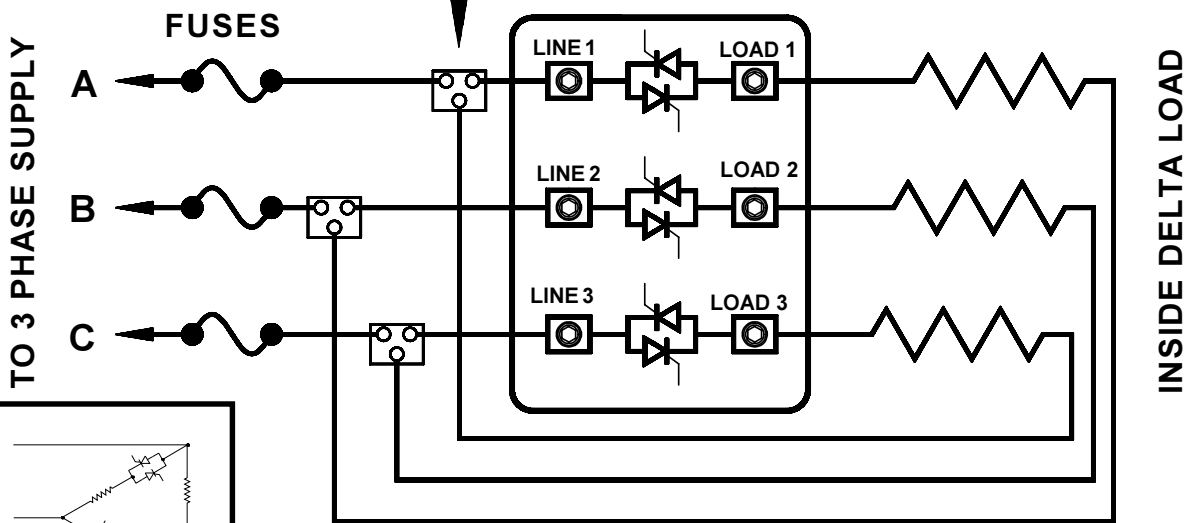
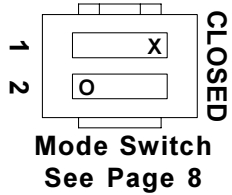

Figure 25. Inside delta power connections.

ELECTRICAL HOOKUPS: (Continued)



Note: It is recommended that the load and controller be protected by 3 class "T" or "Semiconductor fuses. Choose a fuse size approximately 120 to 125% of the current rating of the controller. See page 23 for information.

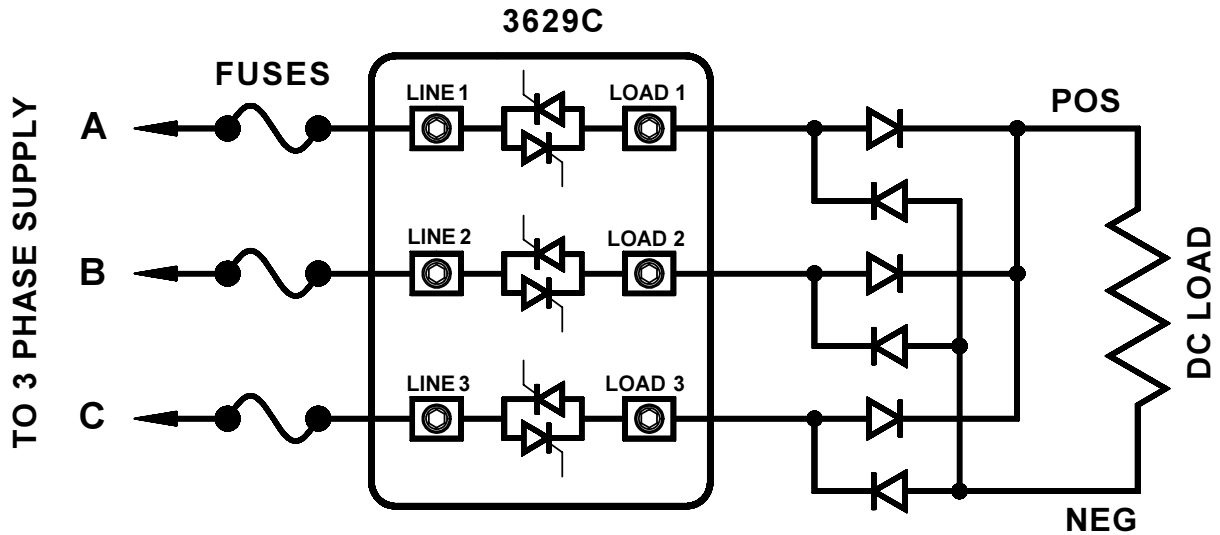

Figure 26. DC power connections.

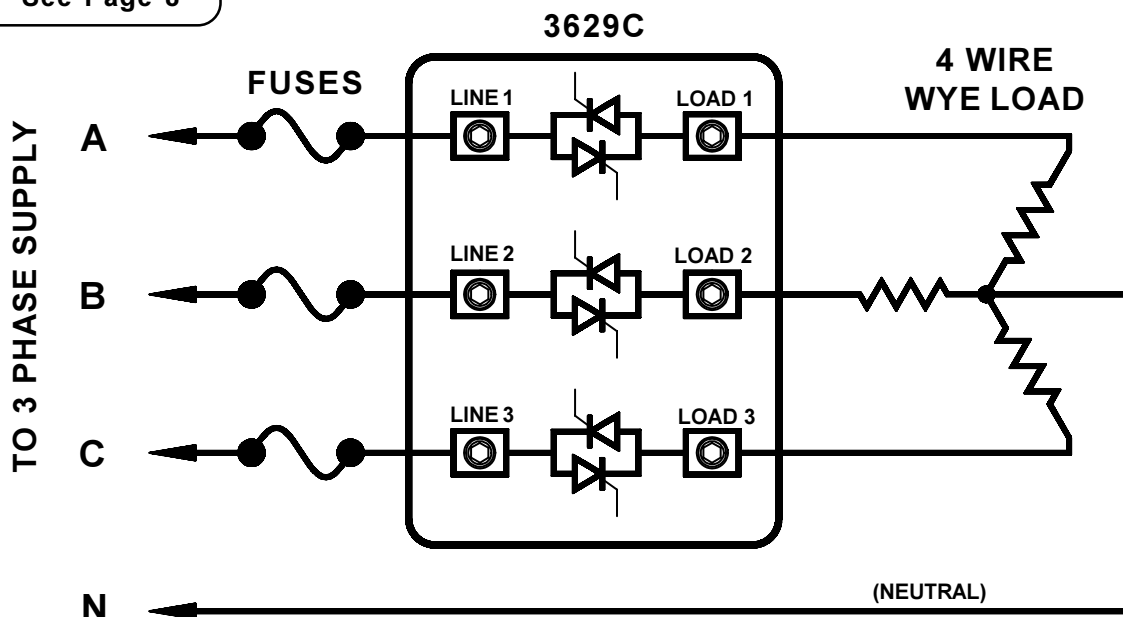
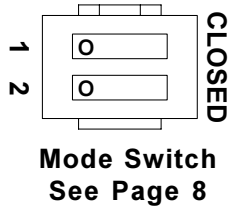
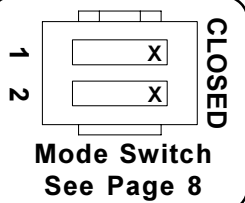

Figure 27. 4 WIRE WYE power connections.

ELECTRICAL HOOKUPS: (Continued)

Note: It is recommended that the load and controller be protected by 3 class "T" or "Semiconductor fuses. Choose a fuse size approximately 120 to 125% of the current rating of the controller. See page 23 for information.



DELTA-WYE TRANSFORMER - With WYE load

Using a Delta primary to a 3 wire Wye secondary transformer into a wye load with an SCR controller is not recommended. If the load across any two legs would happen to open, the high voltages induced across the primary would almost certainly cause the SCR's to fail.

Using a fourth wire, to connect the junction of the secondary Wye to the junction of the Wye load, would eliminate this problem.

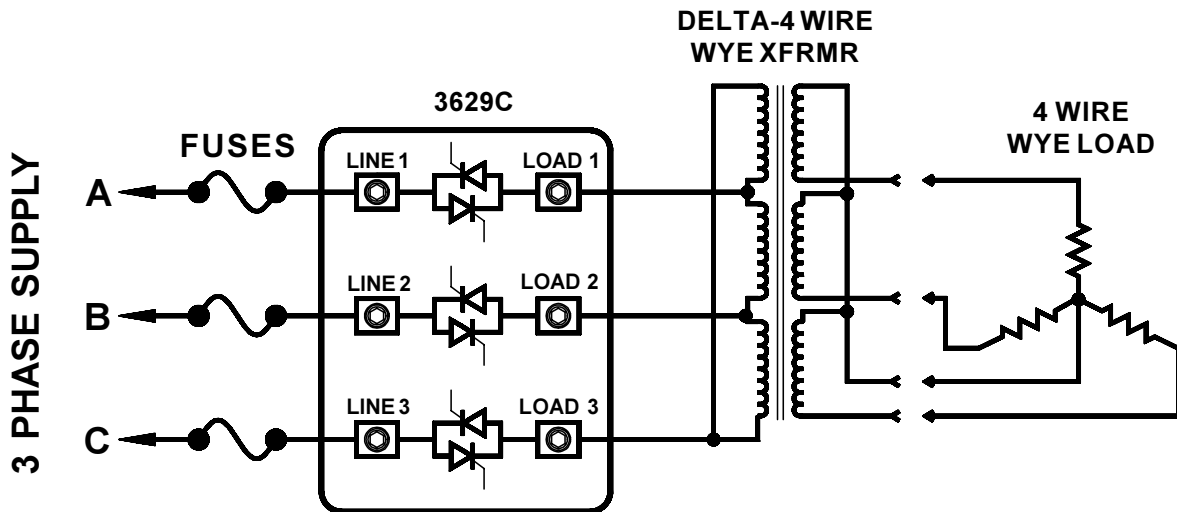
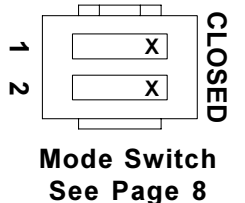

Figure 28. In-Line connection to Delta-Wye Transformer Coupled 4 Wire Wye Load.



DELTA-WYE TRANSFORMER - With DELTA load

Applying a Delta load to the Wye secondary would be less likely to create the same problem, as two loads would have to open to induce high voltages across the primary.

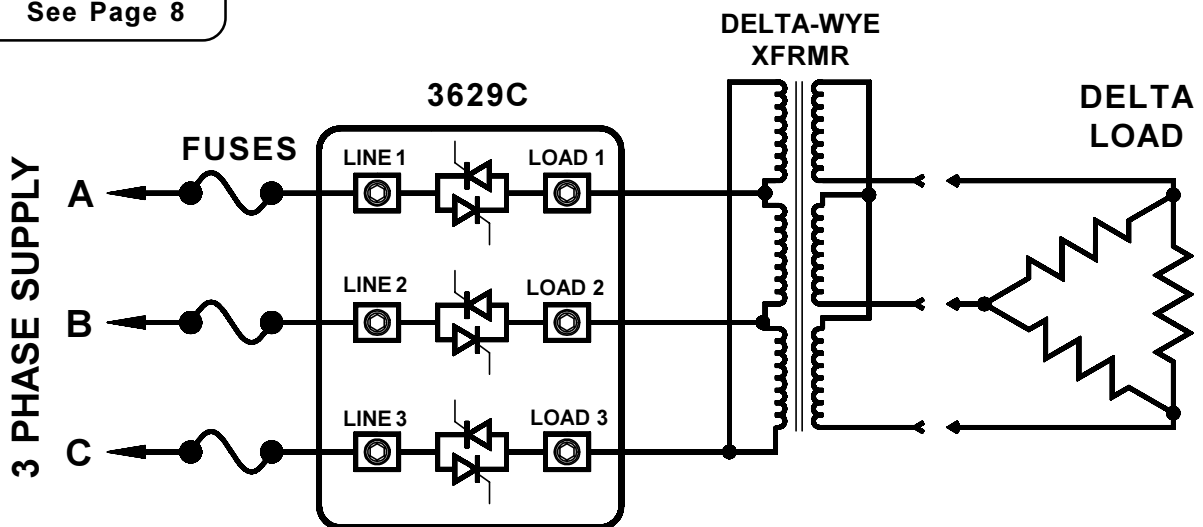

Figure 29. In-Line connection to Delta-Wye Transformer Coupled Delta Load.

TROUBLESHOOTING:

CAUTION:

High Voltage exists on the controller, the circuit board, and other equipment located near the controller. Use extreme caution to avoid electrical shock. Except for voltage and current measurements, remove power before attempting to service this equipment.

Electrical measurements should be made by qualified personnel only.

NOTES

Control Concepts has field service engineers who can help to determine the cause of controller problems. Please call (952) 474-6200 with any questions you may have.

Because of critical assembly requirements on controllers rated 200 Amps or more, it is recommended that the controller be sent to the factory for SCR replacement.

When using average feedback you will get more accurate results if you make your measurements with an average responding meter.

For accurate readings when using RMS feedback, use only a true RMS responding meter.

The controller must have a load capable of drawing at least 1 amp to operate properly.

A circuit board with the exact same specifications may be substituted for a questionable circuit to help identify the location of the problem.

When replacing circuit boards, do not remove wires from the plug-in connector.

SYMPTOMS	POSSIBLE CAUSES
ZERO LOAD POWER. 'LINE OK' LED IS NOT ON:	PHASE MISSING AT LINE INPUT. Check for line voltage at the line terminals. CIRCUIT FUSE CLEARED. Any transformer fuses, when cleared, will cause a loss of power to the firing circuit and will disable the controller. THERMOSTAT OPEN. The thermostat monitors heatsink temperature. When the heatsink temperature rises above 87C, the thermostat will disable the controller. POOR CONNECTIONS. Determine that the frame wiring connectors are plugged fully onto the circuit board connectors.
ZERO LOAD POWER. 'LINE OK' LED IS ON:	COMMAND SIGNAL NOT PRESENT. Determine that a command (set point) signal is present between the CCW and W terminals on the command signal connector. See page 9. INCORRECT COMMAND WIRING. On new installations, check all command wiring and confirm that polarities are correct. OVER CURRENT TRIP HAS OCCURRED. If the O.C.T. LED is lighted, an over current trip has caused the unit to shut down. Close the O.C.T. reset switch or remove power temporarily to reset. CLOSED O.C.T. RESET SWITCH. If a remote over current trip reset switch is used, check that the switch is open. If a remote switch is not used, check that the voltage on terminal 9 is at least 10 Volts with respect to terminal 10.

TROUBLESHOOTING: (Continued)

SYMPTOMS	POSSIBLE CAUSES
LOAD POWER AT MAXIMUM. 'COMMAND' LED IS ON OR OFF.	SHORTED SCR. Check for illuminated "SHORTED SCR" LED. PROBLEM ON THE CIRCUIT BOARD. Remove or swap circuit board to determine if the problem exists on the circuit board.
LOAD POWER AT MAXIMUM. 'COMMAND' LED IS ON	PROBLEM WITH THE COMMAND SIGNAL. Remove the command connector. If load power and line current indicators go off, the problem is associated with the command signal. PROBLEM ON CIRCUIT BOARD. If, after removing the command connector, the command indicator remains on, the problem is probably associated with the circuit board.
LOAD VOLTAGE WILL NOT REACH MAXIMUM.	INSUFFICIENT COMMAND SIGNAL. Determine that the command signal is at maximum. INSUFFICIENT LINE VOLTAGE. Measure the voltage from phase to phase on the line and load terminals. If the voltage is correct at the load terminals but not at the load, check load wiring or external load fuses. CURRENT LIMITING IS ACTIVE. Current limit LED is on. The current limit prevents excessive current when controlling variable resistance loads. It is recommended that the current limit not be changed until the load requirements and the controller ratings are thoroughly understood. INCORRECT SPAN ADJUSTMENT. If the span adjustment pot is adjusted incorrectly, the controller may be unable to reach maximum output. See page 7. INCORRECT LOAD WIRING. On new installations, check the load connections carefully. FAULTY SCR OR CONTROL CIRCUIT. With a digital voltmeter set on the 2000 VDC range, check for a DC voltage present on the load output terminals of the controller. More than 1Vdc between any of the three load outputs could be due to a faulty SCR or control circuit. If the line current indicators are on, the circuit may have failed. If one LED is bright and the others are dim, an SCR or its connections may have failed.

Follow this procedure to determine which SCR is shorted.

- 1. Remove power from controller.**
- 2. Disconnect all Line and load leads from the controller.**
- 3. Measure the resistance between line 1 and load 1 terminals, then between line 2 and load 2 terminals and between line 3 and load 3 terminals.**

If any measurement is less than 1000 ohms, one or more SCR(s) have failed.

RECOMMENDATIONS:

FUSES:

The model 3629C does not have built-in line fuses. It is recommended that the load and controller be protected by using a class "T" or Semiconductor fuse in each of the three line leads.

Bussmann type "JJN" (300 Volts) or "JJS" (600 Volts) are suitable for up to 600 Amp frames.

On frame sizes larger than 600 Amps, a semiconductor type fuse is recommended.

Choose a fuse having a current rating of approximately 120% - 125% of the maximum load current anticipated.

Control Concepts, Inc. stocks a variety of class "T" and semiconductor fuses, as well as fuse blocks and holders, for your convenience.

Consult Control Concepts factory for help to determine the best type and size of fuse to protect your application. (952) 474-6200.

Three Bussmann Class CC type FNQ-R time delay fuses are used for transformer and control circuit protection.

On the 120 and 160 Amp units, the transformer protection fuses are accessible from the outside opposite the line and load connections. On all other units, the fuses are located inside.

The orientation of these class CC fuses is important. Although the fuse may be inserted either way, it will only make contact if oriented in the fuseblock correctly. See page 14 & 15 for illustrations

REPLACEMENT SCR's:

Size of controller

50 Amps
80 Amps
120 Amps
160 Amps

Control Concepts stock number

28325-0395-516
28325-0395-516
28325-0410-516
28345-0413-516

200, 250, 300, 380, 425,
500, 600, 750 & 1000 Amps

Because of critical assembly requirements, it is recommended that replacement of SCRs on 200 Amp and larger controllers be done at the factory.

If you desire to try it yourself, request a copy of our technical bulletin concerning replacement of SCR's on the 3629 controller.

REFERENCE DRAWINGS:

Firing circuit schematic.	D1001160B
Frame wiring diagram, 50 & 80A.	CS1569A
Frame wiring diagram, 120A.	CS1574A
Frame wiring diagram, 160A.	CS1570A
Frame wiring diagram, 200-425A.	CS1571C
Frame wiring diagram, 500-1000A.	CS1575C

MANUFACTURED BY:

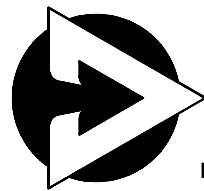

**CONTROL
CONCEPTS**

Distributed Worldwide By
www.mcgoft-bethune.com
Email: sales@mcgoft-bethune.com
1-800-303-4705
+1-770-840-9811

MODEL NUMBER IDENTIFICATION:

3629C-(FB)-(VOLTS)-(AMPS)-CS-IL(Amps)-(SC)-(OCT)-(SP-##)

Basic Model Number _____

Specifies Type of Feedback _____

V specifies RMS voltage feedback.

(Desired for heating applications.)

A specifies Average voltage feedback.

(Desired in some DC applications.)

E specifies external feedback.

Specifies Supply Voltage. _____

Typical choices are: **208, 240,**

380, 415, 480 or 575 Volts AC

Other voltages may be available,
call factory for details.

Specifies: Current Rating of the Controller. _____

Frame sizes are: **50, 80, 120, 160, 200, 250,**

300, 380, 425, 500, 600 or 750 Amps

An unlisted **1000** Amp controller is available.

Specifies Command Signal. _____

0-5Vdc or **Potentiometer** input are standard.

0-10 Vdc can be used after placing a jumper
on the circuit board. (Page 8)

Non-standard as well as mA input commands may be requested
at time of order.

If a potentiometer is used, 1K ohm is recommended for greater linearity,
up to 20K ohm is permissible.

Specifies Current Limit. _____

Adjustable: Useable range of 20 to 125% of frame rating.

If not specified, current limit will be factory set to 105%
of specified frame current.

(Optional) Specifies Special Calibration. _____

Contact factory for details.

(Optional) Specifies Over Current Trip setting. _____

(If not specified, O.C.T. will be set to 175% at factory.)

(Optional) Specifies Special Product _____

Contact factory with questions.

Examples:

3629C-V-480V-200A-4/20mA

This model number specifies a three-phase, 6 SCR, Phase-Angle controller, with true RMS voltage feedback, for 480 Volt operation at 200 Amps maximum and is factory modified to accept a 4/20mA command signal.

3629C-A-240V-160A-0/5V

This model number specifies a three-phase, 6 SCR, Phase-Angle controller, with average voltage feedback, for 240 Volt operation at 160 Amps maximum and accepts a 0 to 5Vdc command signal.