

**CONTROL
CONCEPTS
INC.**

**INSTRUCTION MANUAL
MODEL 3037**

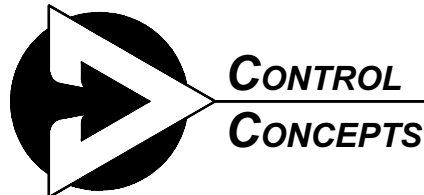

Distributed Worldwide By
www.mcgoff-bethune.com
1-800-303-4705
+1-770-840-9811

DESCRIPTION:

MODELS COVERED

This manual covers the model 3037 controller rated 85 amps through 425 amps.

APPLICATIONS

The model 3037 provides control of three phase power to a variety of loads, including electric ovens, furnaces and kilns, environmental chambers, contactor replacement, resistance heating, platen heaters and extruders.

GENERAL DESCRIPTION

The model 3037 is a three-phase, two leg, zero cross power controller. The average output voltage is proportional to the command signal.

The model 3037 is not sensitive to phase rotation.

A jumper is provided for selecting between external, or average voltage internal feedback. Other jumpers select between several types of command signals.

Sync-Guard and Trans-Guard features are built into the model 3037.

The model 3037 has shorted SCR detection.

MODEL NUMBER:

3037-[vvv]V-[aaa]A-[xx]-[FC]-[SC]

3037 specifies a three-phase, two leg SCR controller.

[vvv] specifies the line voltage.
Choices are: 208, 240, 277, 380, 415, 480 or 575 Vac. Consult factory for other voltages.

[aaa] specifies the continuous RMS load current rating.
Choices are: 85, 145, 175, 240, 295, 370, or 425 Amps.

The "**[xx]**" term specifies the type of command signal the controller has been factory calibrated to operate with.

Choices are:

Voltages: 0 to 5Vdc or 0 to 10Vdc.

Current: 4/20mA.

Potentiometer, 1K Ω to 20K Ω .
1K Ω recommended.

Contact factory for additional command signal possibilities.

The "**[FC]**" term specifies a replacement firing circuit only. This term is omitted when ordering complete controller.

The "**[SC]**" term specifies special calibration. This term is omitted if standard calibration is desired.

For example, **3037-480V-295A-4/20mA** specifies a three phase 3037 controller built to operate on a 480 volt line, 295 amps continuous load current and operate over a command signal range of 4 to 20mA.

SPECIFICATIONS:

These specifications apply over an ambient temperature of 0 to 55°C; supply voltage of 208, 240, 277, 380, 415, 480 or 575 Vac (+10% - 15%); and 50/60 Hertz.

CONSTRUCTION:	The firing circuit, gate drivers and all associated circuitry is laid out on a single Board. Three fast acting fuses, inside the controller, protect the SCRs from typical fault currents.										
CONTROL MODE:	The model 3037 SCR power controller, linearly controls with respect to a command signal, the electrical power applied to three-phase resistive load by zero-cross operation of silicon controlled rectifiers (SCRs). The controller provides line voltage compensation which maintains the load power constant, independent of line voltage variations.										
FIRING MODE:	2 leg distributed zero cross. Average load voltage is proportional to the command signal when using internal feedback.										
CONTROL RANGE:	0 to 100% of supply voltage.										
CONTROL POWER:	24 Vac + 20% - 15%. VA = 15										
DV/DT AND TRANSIENT VOLTAGE PROTECTION:	DV/DT rating exceeds 200 volts per microsecond. DV/DT snubber circuit and MOVs are provided to protect against high frequency transients (dv/dt) and high voltage transients.										
SETPOINTS	<p>The command signal may be either a mA current, a DC voltage or a potentiometer. The 3037 provides electrical isolation of the command signals from the line and load voltages allowing grounded or ungrounded commands.</p> <p>The following command signal inputs are jumper selectable:</p> <table style="margin-left: 40px;"> <thead> <tr> <th>Input Signal</th> <th>Input Impedance</th> </tr> </thead> <tbody> <tr> <td>4/20 mA</td> <td>249 Ohms</td> </tr> <tr> <td>0-5 Vdc</td> <td>500k Ohms</td> </tr> <tr> <td>0-10 Vdc</td> <td>200K Ohms</td> </tr> <tr> <td>1K - 20K Pot</td> <td>200K Ohms</td> </tr> </tbody> </table> <p>(A 1K, 1/4 watt potentiometer is recommended for optimum linearity, up to 20K is permissible) The potentiometer is excited by 10Vdc, supplied by the circuit. Other ranges may be available. Check with factory for special applications.</p> <p>Plus or minus 200 Volt Peak isolation is provided for the 4/20 mA input by means of a high common mode voltage instrumentation amplifier.</p>	Input Signal	Input Impedance	4/20 mA	249 Ohms	0-5 Vdc	500k Ohms	0-10 Vdc	200K Ohms	1K - 20K Pot	200K Ohms
Input Signal	Input Impedance										
4/20 mA	249 Ohms										
0-5 Vdc	500k Ohms										
0-10 Vdc	200K Ohms										
1K - 20K Pot	200K Ohms										

SPECIFICATIONS:			
ENVIRONMENT:	Operating temperature:	0 to 55°C (32 to 132°F)	
	Storage temperature:	-20 to 80°C (-4 to 176°F).	
	Humidity:	0 to 95%, Non condensing.	
EXTERNAL FEEDBACK:	0 to 5 Vdc feedback signal.		
DISSIPATION:	Approximately 1.5 watts per amp of current per phase will be dissipated by the controller.		
FRAME SIZES AND FUSING	<p>The 85 Amp frame is fused at 110 Amps maximum. The 145 Amp frame is fused at 175 Amps maximum. The 175 Amp frame is fused at 200 Amps maximum. The 240 Amp frame is fused at 300 Amps maximum. The 295 Amp frame is fused at 350 Amps maximum. The 370 Amp frame is fused at 450 Amps maximum. The 425 Amp frame is fused at 500 Amps maximum.</p>		
GATE DRIVES:	Optically coupled Triac drivers.		
LINEARITY:	The average load voltage is linear within 2% of span with respect to the command signal.		
PHASE ROTATION:	The model 3037 is not sensitive to phase rotation. Exchange of line leads is unnecessary.		
SCR I²T AND SURGE CURRENT RATING:	Frame rating	SCR I ² T rating @25°C	I _{TSM} Surge Current Rating @25°C
	85 Amps	20,000A ² s	2000A
	145 Amps	20,000A ² s	2000A
	175 Amps	110,000A ² s	4700A
	240 Amps	110,000A ² s	4700A
	295 Amps	145,000A ² s	5400A
	370 Amps	361,000A ² s	8500A
	425 Amps	405,000A ² s	9000A
SCR VOLTAGE RATING:	1400 volts peak		
SCR CONFIGURATION:	2 inverse-parallel SCR switches In-Line, driving a 3 wire wye or delta load arrangement.		

SPECIFICATIONS:

SHORTED SCR DETECTION:	<p>Shorted SCR detection will be accomplished by measuring the Voltage across the SCR switch when the Gate Signal is off. A measurement of less than 24 Volts across the SCR switch indicates a shorted SCR.</p> <p>Non-latching form "C" relay contact closes when a shorted SCR is detected.</p> <p>The shorted SCR relay is rated at 120 Vac, with a 5 Amp resistive load.</p> <p>If an open line or open load results in zero voltage across an SCR switch, the shorted SCR detector will be energized.</p>
SYNC-GUARD	<p>"Sync-Guard" reduces the possibility of two or more controllers operating synchronously, thereby reducing the possibility of all controllers being on and off simultaneously. The "Sync-Guard" feature provides a more uniform or continuous power demand and therefore reduces the variations in the supply voltage that can occur when multiple controllers operate synchronously.</p> <p>Up to ten controllers may be connected together for synch-guard. Only one termination resistor should be connected in each group of controllers tied together in this way.</p>
TRANS-GUARD:	<p>The "Trans-Guard" feature eliminates the DC load voltage and current that can exist with zero-cross operation. The "Trans-Guard" feature therefore prevents saturation and over heating of supply transformers due to DC voltage which can occur on the transformer primary because of secondary DC currents.</p>
VOLTAGE COMPENSATION:	<p>The load power remains constant within 2% of span for line voltage changes of +10% and -15% variations.</p>
LED INDICATORS:	<p>Command indicator. 2 shorted SCR indicators.</p>
ZERO AND SPAN ADJUSTMENTS:	<p>Multi-turn potentiometers allow zero and span adjustments of $\pm 25\%$ of span.</p>
ISOLATION:	<p>Isolation between power circuit, command signal and ground is greater than 2500 Vrms.</p>

THEORY OF OPERATION:

In zero-cross control, load power is turned on or off only when the instantaneous value of the sinusoidal waveform is zero. Load power is controlled by switching the SCRs "on" for a number of electrical half-cycles and then "off" for a number of electrical half-cycles. The odd "on" and even "off" cycle is a result of the Trans-Guard feature.

The following tabulation shows the number of "on" and "off" electrical half-cycles of power that are applied to the load to achieve the percentage of load power indicated. The percentage of load power is equal to the ratio of the number of electrical half-cycles that power is applied to the total number of electrical half-cycles.

Load Power / ON-OFF time.				
10%	25%	50%	75%	85%
5on	5on	9on	17on	23on
46off	14off	8off	6off	4off
5on	5on	7on	19on	23on
44off	16off	8off	6off	4off
				23on
				4off
				23on
				4off
				23on
				4off
				21on
				4off

From the above tabulation, it can be seen that power is applied for 16 out of 32 electrical half-cycles to achieve 50% load power and that power is applied for 136 out of 160 electrical half-cycles to obtain 85% power. When operated with a 60 hertz supply, the sequence of on and off cycles repeats every 0.266 seconds at 50% and every 1.33 seconds at 85% power. Note that even though it takes 1.33 seconds to obtain precisely 85% power, the load power during the 23 on and 4 off cycles is 23/27 or 85.185% power and that this cycle is repeated every 0.225 seconds.

ADJUSTMENTS:

THE ZERO AND SPAN POTENTIOMETERS ARE FACTORY SET, AND SHOULD NOT REQUIRE FURTHER ADJUSTMENT.

If adjustments become necessary, the following procedure should be followed.

1. Set the command signal to minimum and adjust the zero potentiometer until the output is zero. If this pot is set incorrectly, the output of the controller may not be linear with respect to the command signal, or, the controller may be unable to shut off completely.
2. Set the command signal to maximum and adjust the span potentiometer until the LED lights constantly.

NOTE: The LED will blink once every five seconds, during maximum signal, while the circuit is testing for a shorted SCR

If this pot is set incorrectly, the output of the controller may not be linear with respect to the command signal, or the controller may be unable to reach full output.

3. The span and zero adjustments may interact, therefore it may be necessary to repeat steps 1 and 2.

Do not attempt to adjust the offset potentiometer, this adjustment is made at the factory and is critical to proper operation of the controller with 4/20mA commands.

INSTALLATION:

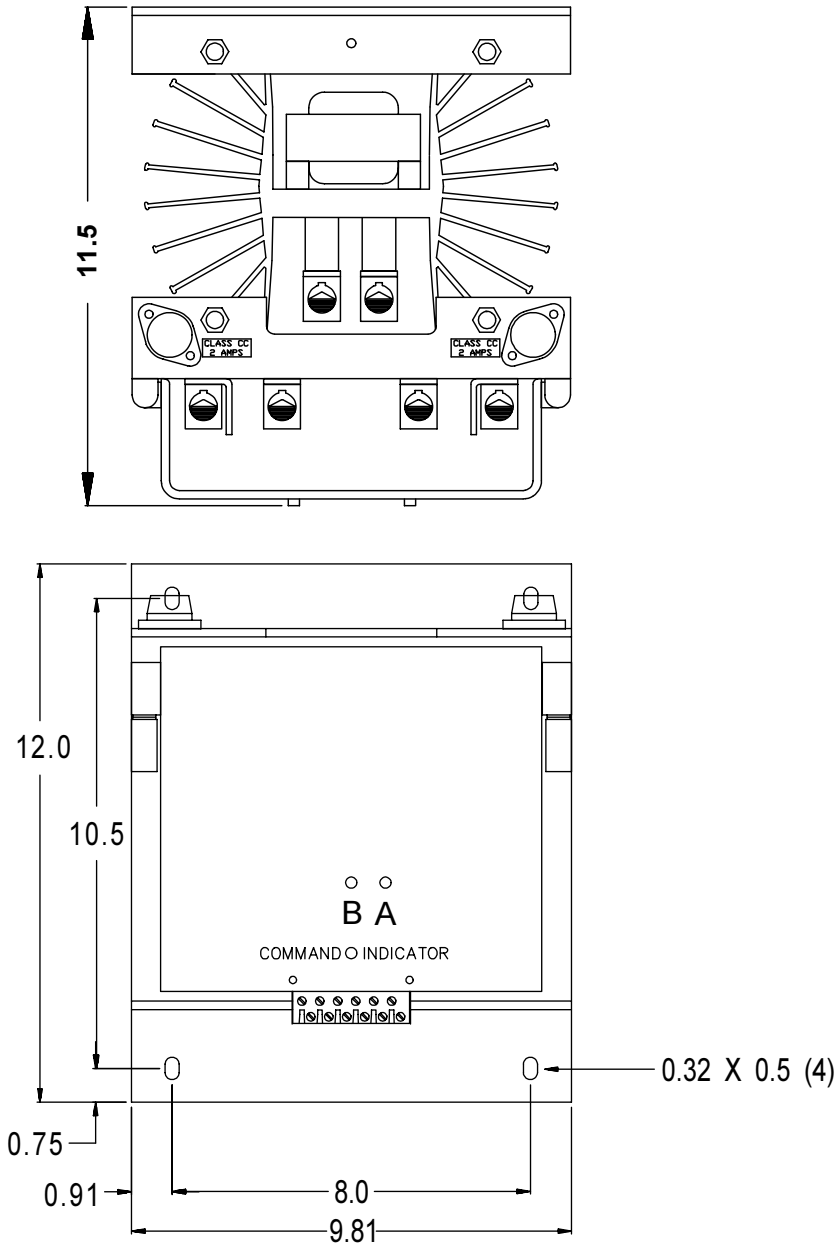
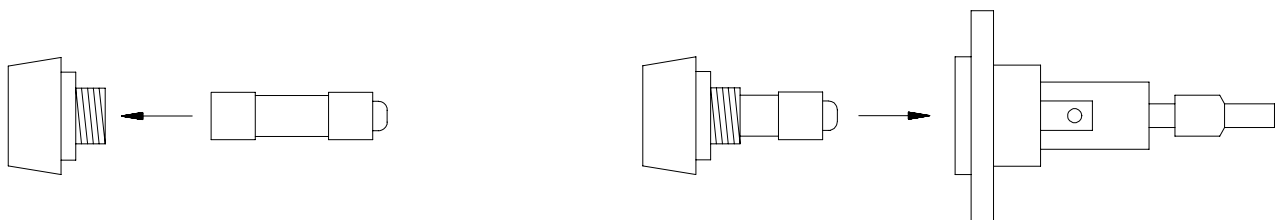

Figure 1. Mounting dimensions, Model 3037, 85, 145 and 175 Amps
(145 & 175 Amp units have forced air cooling.)



ORIENTATION OF FUSE IN HOLDER

Fuse makes contact only when correctly installed.
Place flat end of fuse in cap, then insert into holder.

INSTALLATION:

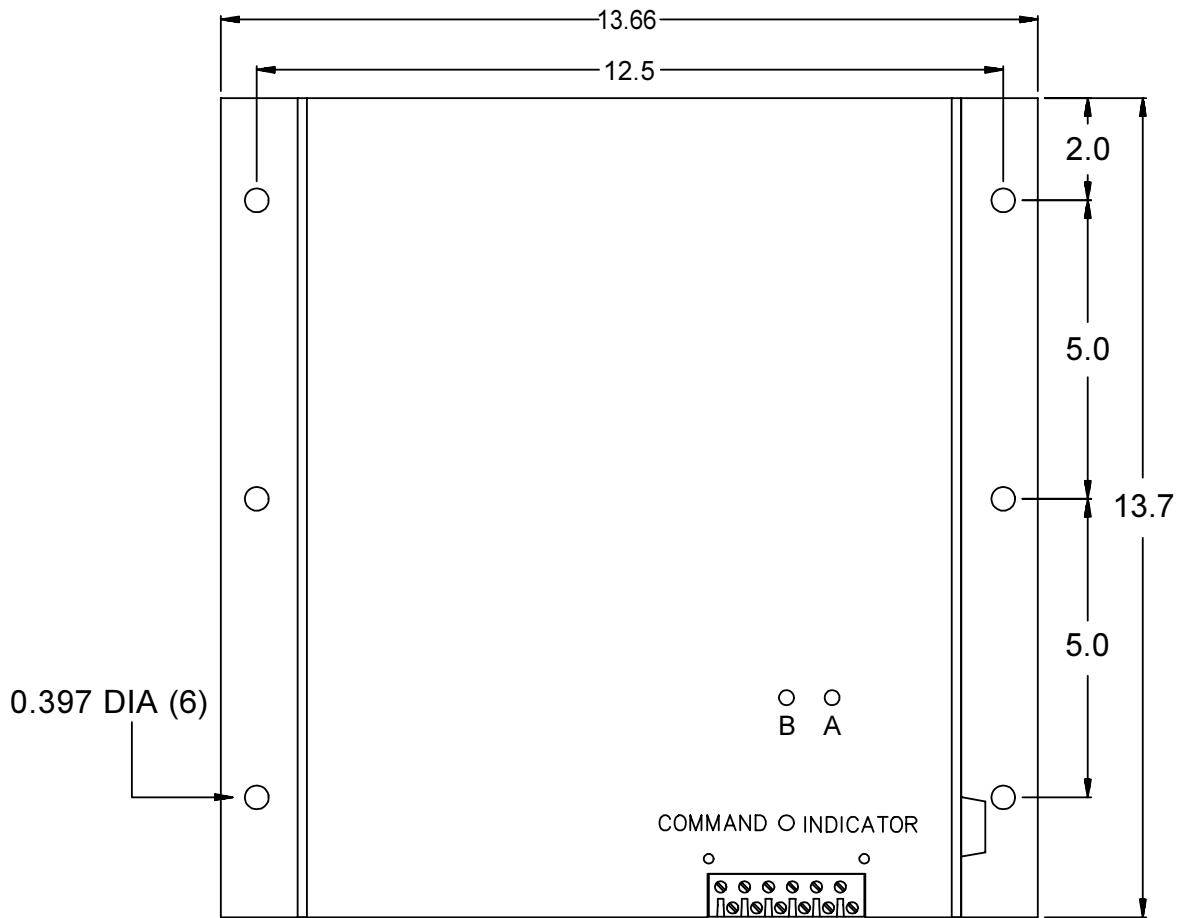
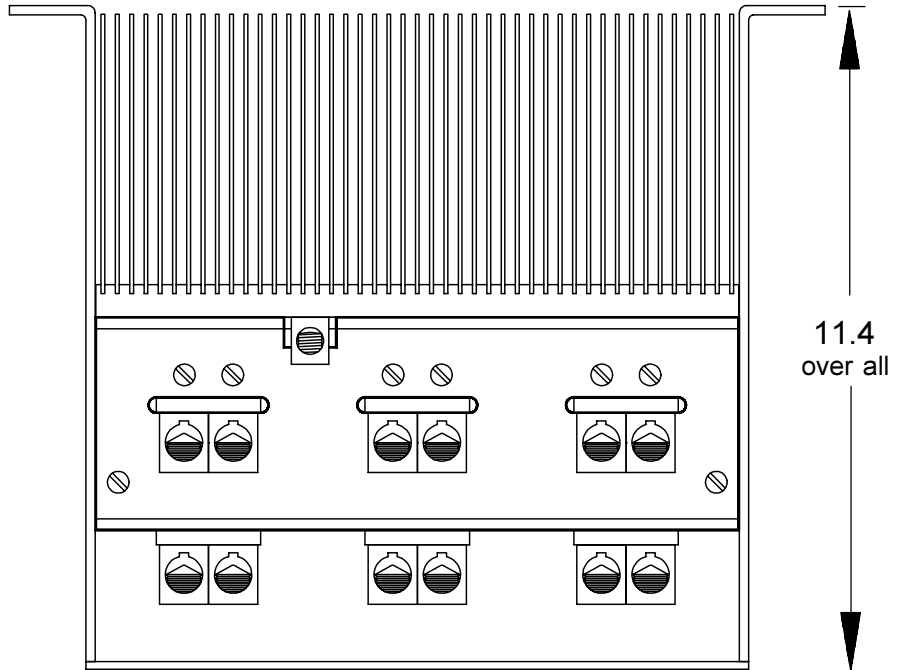

Figure 2. Mounting dimensions, Model 3037, 240 to 425 Amps.
SEE PAGE 6 FOR FUSE ORIENTATION

INSTALLATION:

SHORTED SCR DETECTION RELAY

A relay with form "C" contacts rated at 120 Vac @ 5A is located on the circuit board. These contacts may be used to operate a contactor which would remove power from the circuit and/or cause an alarm to signal personnel.

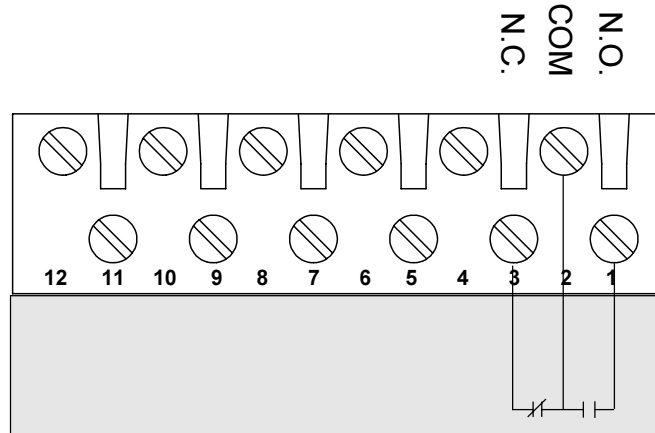

Figure 3. Connections for shorted SCR detection relay.

SYNC-GUARD:

The Sync-Guard feature is implemented by connecting all #11 terminals together, and all #12 terminals together. Up to 10 controllers, regardless of the current ratings, can be connected in this manner. A jumper is left in place from P3-11 to P3-12 on any one of the controllers, the other controllers must have this jumper removed. The unused jumper may be stored as shown below.

This jumper connects a 1K load resistor in the Sync-Guard circuit, only one is necessary.

Do not remove jumpers from other pins. See pages 9, 10 & 11.

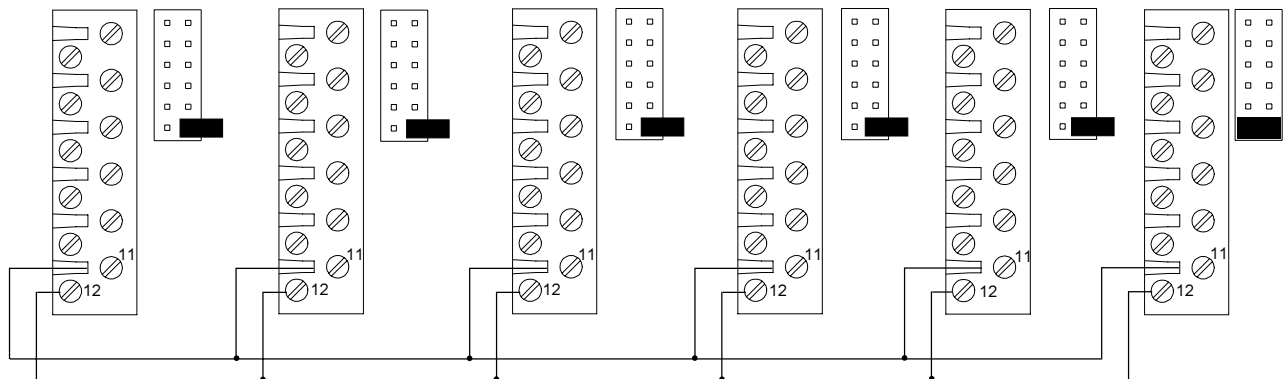

Figure 4. Connecting units together for sync guard.

INSTALLATION:

HOW TO CONNECT EXTERNAL FEEDBACK TO THE MODEL 3037

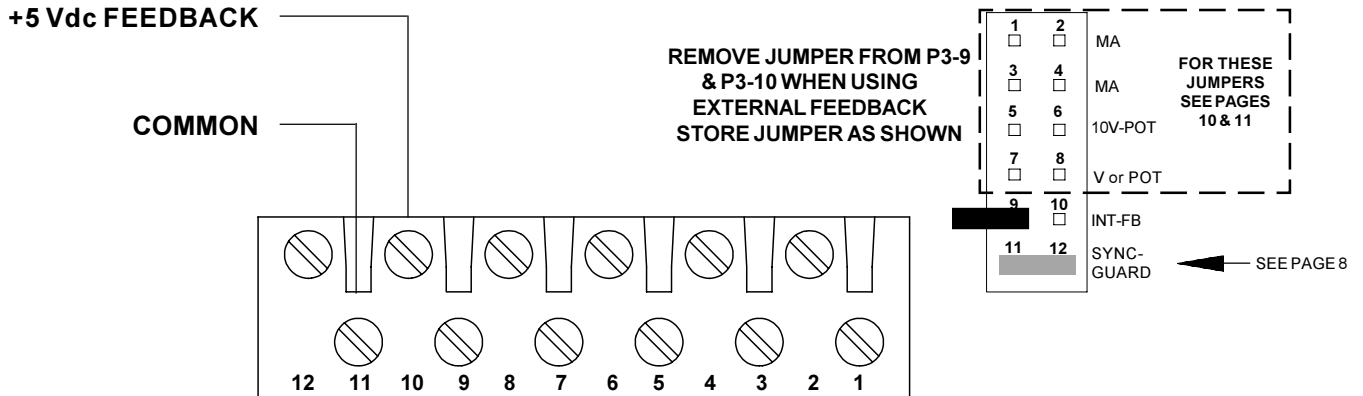

Figure 5. External feedback is a 0 to 5 Volts D.C. signal representing the variable to be controlled. For example; Power, Current, Voltage, ETC.

USE EXTREME CAUTION TO AVOID ELECTRICAL SHOCK
Portions of the electronic circuit and other parts of the controller are at line voltage.

BEFORE MOUNTING, DETERMINE THAT THE TRANSFORMER TAP IS SET TO A VALUE CORRESPONDING TO THE SUPPLY VOLTAGE.

POWER CONNECTIONS:

Wire the controller in accordance with the electrical codes for the area in which it will be used.

Connect the supply power and load as shown in the electrical installation drawing on page 12.

NOTE: The controller is not phase rotation dependent.

The connectors are rated for use with wire sizes from 250MCM to 6.

Type THWN or THNN wire is recommended and an oxide inhibitor such as Burndy Penetrox a, Ideal No-Alox or IlSCO De-OX be used to insure good electrical connections.

See pages 12 & 13 for command signal wiring diagrams.

Recommended tightening torque for the connectors are:

Wire Size (circ mills)	Torque (inch-pounds)
6	100
4	100
2	125
1	125
1/0	150
2/0	150
3/0	200
4/0	200
250MCM	250
500MCM	250

Set the command signal to minimum and apply system power. The command indicator light should be off and no power should be applied to the load. Slowly increase the command signal. The command indicator should blink on and off proportional to the magnitude of the command signal and load power should increase. If the command indicator blinks on and off with no command signal, adjust the "zero" potentiometer until the indicator no longer turns on. If the command indicator blinks when the maximum command signal is applied, adjust the "span" potentiometer until the indicator blinks only once every 5 seconds. (See note on page 5.)

CONTROL CONNECTIONS:

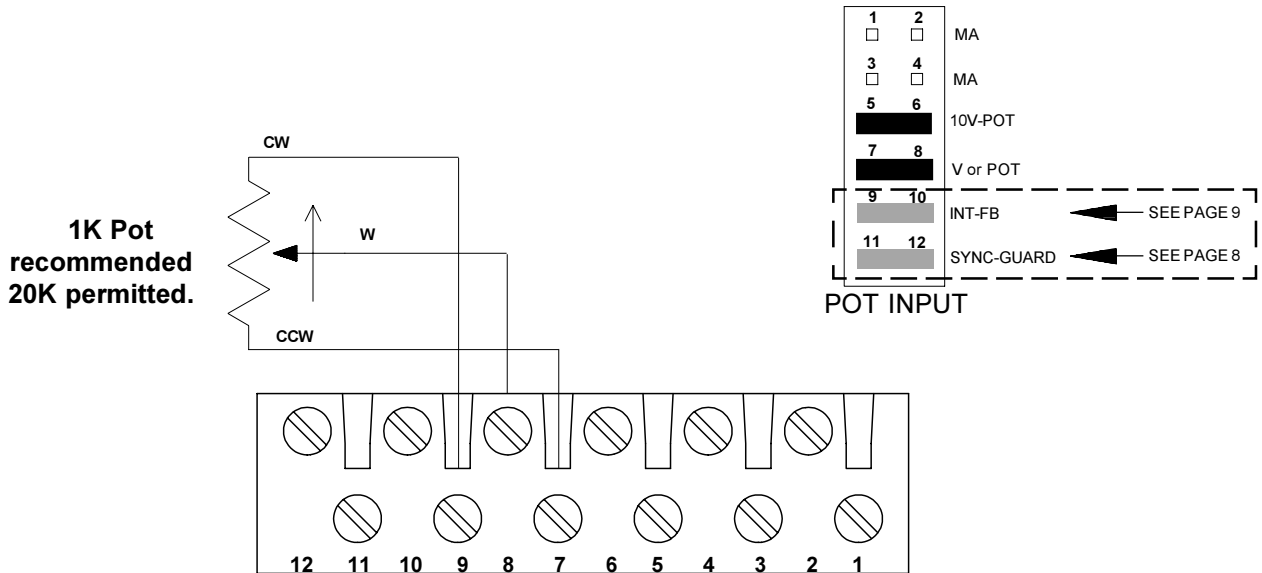

Figure 6. Connections for using a pot as a command control.

POTENTIOMETER INPUT:

1K recommended, 20K maximum resistance. 1/2 watt

Clockwise terminal to terminal 9

Wiper terminal to terminal 8

Counterclockwise terminal to terminal 7

Note: If multiple controllers are controlled by one potentiometer, make the connections as described above for one controller and connect terminal 7 to all other controllers and terminal 8 to all other controllers. If run/idle control is desired, use two potentiometers (2K minimum resistance) and switch the appropriate potentiometer wiper to the controller.

Note: Shielded control wiring is not required, however, it is recommended that the control wire not be placed adjacent to the power wiring.

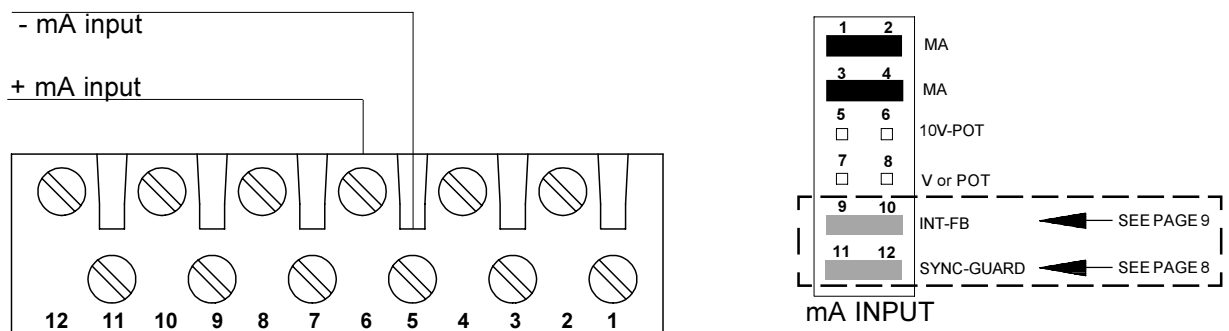

MA INPUT: COMMON TO TERMINAL 5, + INPUT TO TERMINAL 6

Figure 7. Connections for a mA command signal.

CONTROL CONNECTIONS:

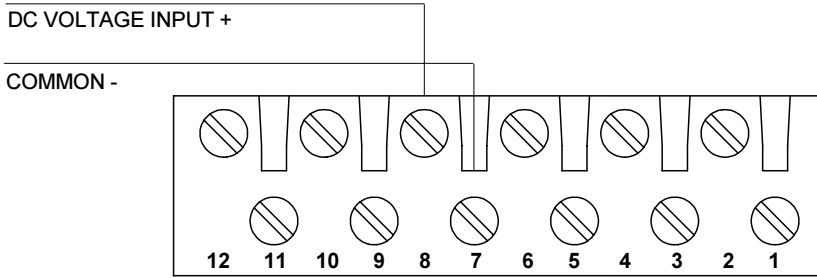

Figure 8. Connections for a voltage command signal.

VOLTAGE INPUT:

0 to 5 Vdc:

Common to terminal 7, 5 Vdc to terminal 8,
Jumper between P3-7 & P3-8

0 to 10 Vdc:

Common to terminal 7, 10 Vdc to terminal 8,
Jumpers between P3-5 & P3-6 and P3-7 & P3-8

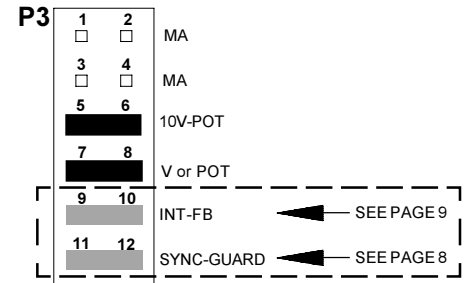
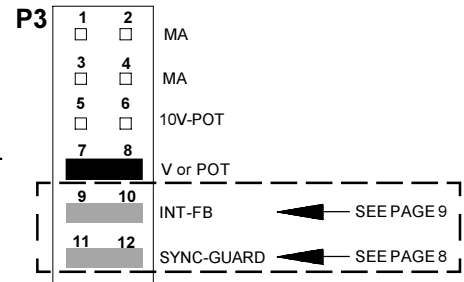

Figure 9. Jumper positions for Voltage inputs.

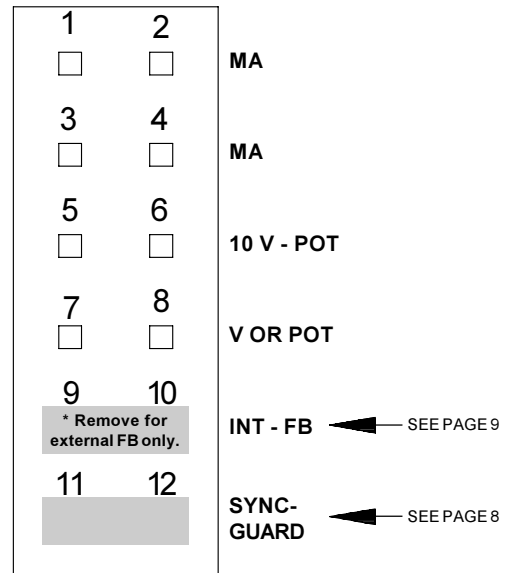
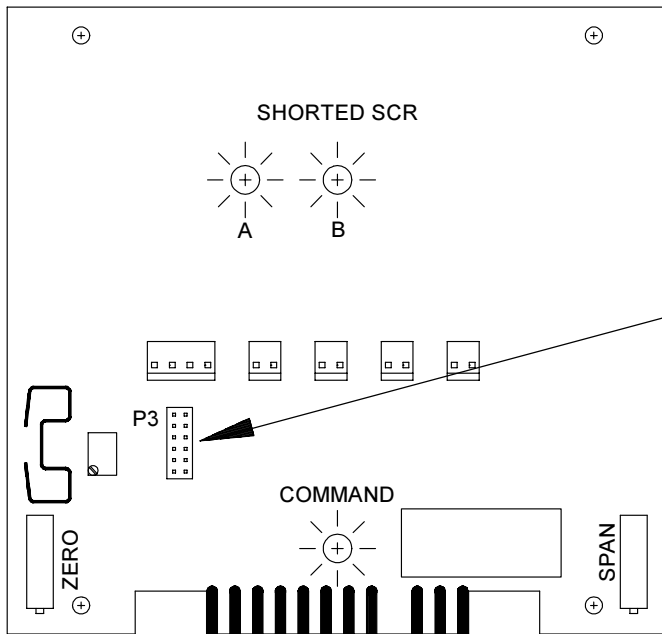
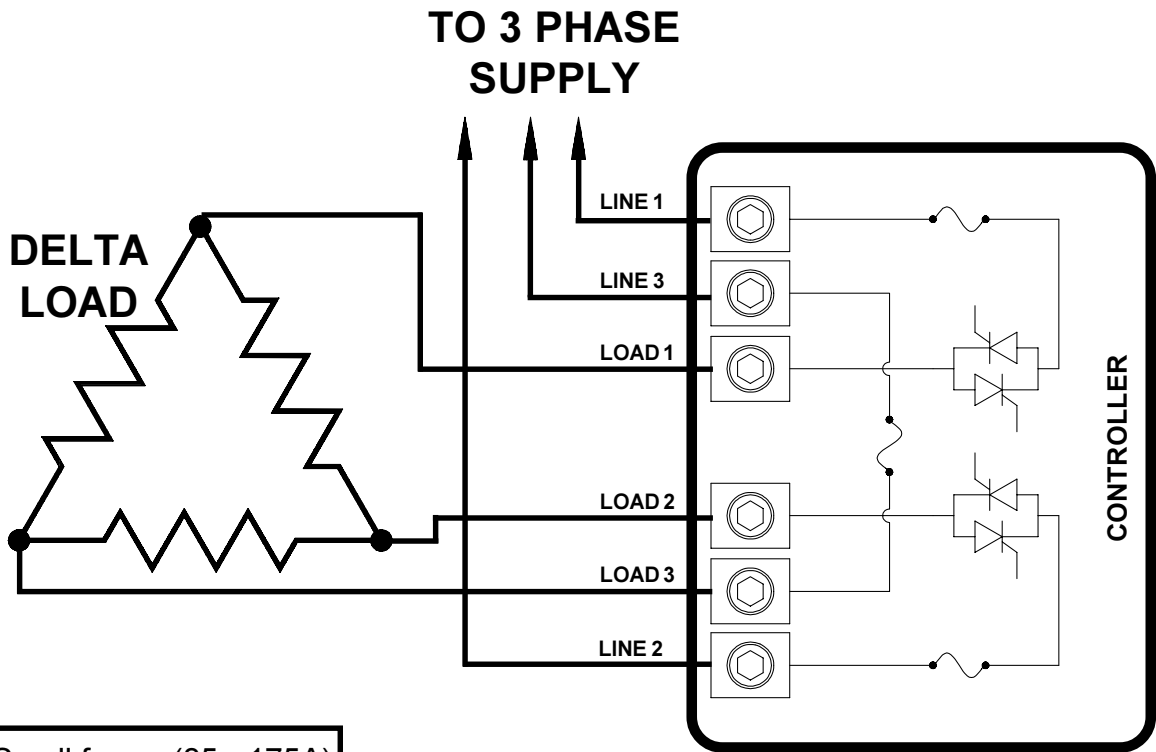

Figure 10. P3 jumper positions

POWER WIRING:



NOTE: Small frame (85 - 175A) has one lug per connection. Large frame (240 - 425A) has two lugs per connection.

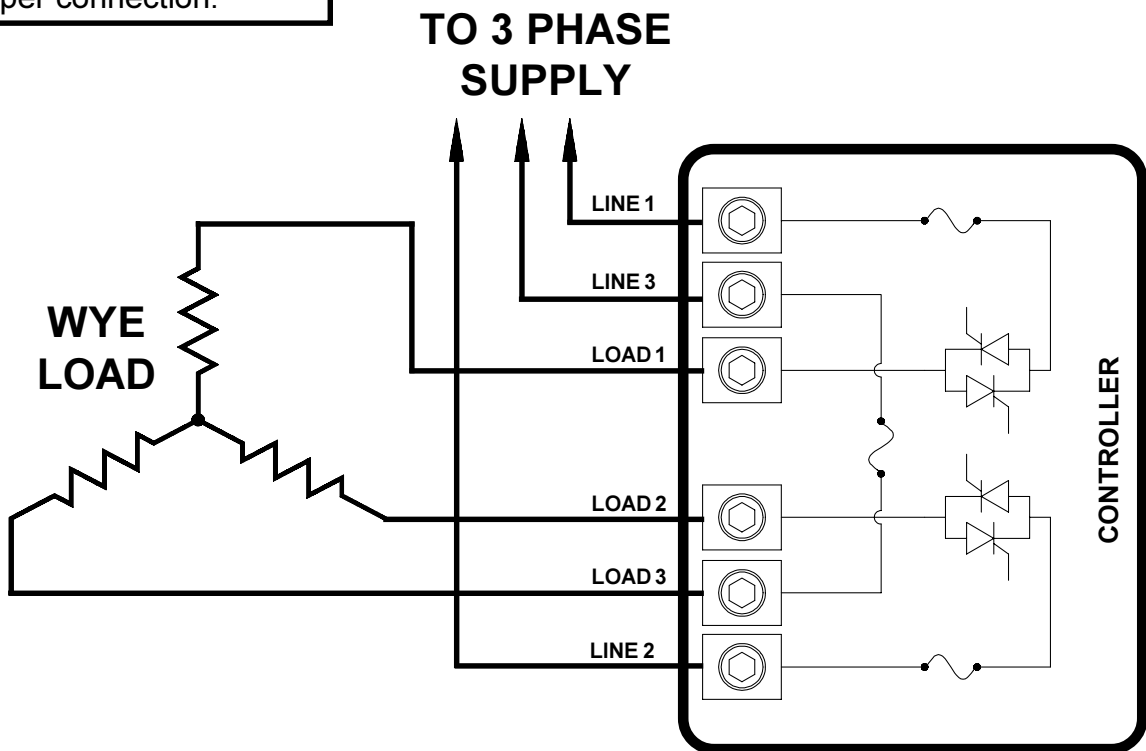

Figure 11. In-line power connections.

TROUBLE SHOOTING:

**USE EXTREME CAUTION TO AVOID ELECTRICAL SHOCK
DO NOT ATTEMPT TO OPERATE THE CONTROLLER
WITH THE CATHODE OR GATE LEADS REMOVED
THE FOLLOWING ARE POSSIBLE SYMPTOMS AND PROCEDURES TO FOLLOW.**

NO LOAD POWER AND COMMAND INDICATOR DOES NOT FUNCTION.

1. Determine that line voltage is present on line input terminals.
2. Check fuses.
3. Determine that the command signal is present.
4. Determine that 10 Vdc \pm 0.5V is present between terminal 7 and terminal 9 on the input connector.
 - a. If the voltage is greater than 11 Vdc, the circuit board has probably failed.
 - b. If the voltage is less than 9 Vdc, the circuit board or transformer has probably failed.
(Check that correct transformer tap has been selected.)
 - c. If the voltage is zero, check to see if a power transformer fuse is blown.

NO LOAD POWER AND COMMAND INDICATOR FUNCTIONS CORRECTLY.

1. Remove system power and visually inspect circuit board for damage.
2. It is unlikely that all SCR modules have failed.
3. Check load connections and load fuses.
4. Check that gate connector is plugged in and properly seated.

PARTIAL LOAD POWER AND COMMAND INDICATOR IS OFF.

1. Remove system power and remove circuit board from the controller. Reapply system power. If no load voltage exists with the circuit board removed, the circuit board has failed.
2. If voltage still exists across load, one or more SCR's has failed.

FULL LOAD POWER: COMMAND INDICATOR IS ON. NO SSCR INDICATOR ON. COMMAND SIGNAL IS LESS THAN MAXIMUM.

1. (A convenient method to apply zero command is to remove the input connector from the controller.)
If the command indicator remains on with zero command signal the circuit board has failed.
2. Missing external feedback signal with jumper P3-9 to P3-10 removed.

FULL LOAD POWER CAN NOT BE OBTAINED AND COMMAND INDICATOR IS ON.

1. Check the fuse between line 3 and load 3.
2. Visually inspect the circuit board for damage.
3. With the command signal at maximum the voltage between the corresponding line and load terminals should be less than 5 Vac. SCR modules which have a voltage greater than 5 volts have probably failed.

ONE OR MORE SHORTED SCR INDICATORS IS ON.

1. SCR associated with that phase is shorted.
2. Faulty load wiring.
3. Blown fuse.
4. With power off, remove the firing circuit. Reapply power. One or more SCR's have failed if load voltage exists.

SPARE PARTS LIST:

REPLACEMENT SCR

Frame size	CCI Part No	Seco - West No.	SemiKron No.
85 Amps	28325-0395-514	STT-091-M14M	SKKT- 91-14D
145 Amps	28325-0395-514	STT-091-M14M	SKKT- 91-14D
175 Amps	28345-0413-514	STT-132-M14M	SKKT-132-14E
240 Amps	28355-0416-514	STT-170-M14M	SKKT-161-14E
295 Amps	28355-0416-514	STT-170-M14M	SKKT-161-14E
370 Amps	28355-0421-514	STT-210-M14M	SKKT-210-14E
425Amps	28355-0425-514	STT-250-M14M	SKKT-250-14E

CLASS "T" REPLACEMENT FUSES

Frame size	CCI Part No.	Bussmann No.
85 Amps	42110-0460-411	JJS - 110
145 Amps	42110-0460-417	JJS - 175
175 Amps	42110-0460-420	JJS - 200
240 Amps	42110-0460-430	JJS - 300
295 Amps	42110-0460-435	JJS - 350
370 Amps	42110-0460-445	JJS - 450
425 Amps	42110-0460-450	JJS - 500

CLASS "CC" TRANSFORMER FUSES

Fuse size	CCI Part No.	Bussmann No.
1 Amp	42130-0460-210	FNQ-R-1

MANUFACTURED BY:

